

The Boobytrap Recognition Manual

Volume 5

Yugoslavian Boobytrap Mechanisms



George Zahaczewsky & Bob Gravett

Edited by D.W. Lynn

2026

Copyright © George Zahaczewsky & Bob Gravett

2025

Revised update 2026

Email gzahaczews@aol.com

This is a free publication, not to be sold.

If used as a reference in other publications credit should be given in the bibliography.

INTRODUCTION

This publication continues the series of “The Boobytrap Recognition Manual” originally created by D.W. Lynn and, as he said in his very first introduction, it is “a result of frustration trying to find those little tidbits of information that are spread throughout many books, manuals and papers.” The team that created this publication consisted of George Zahaczewsky and Bob Gravett, as well as D.W. Lynn, who provided his expertise in final editing and formatting. We all hope that you will find the contents both informational as well as potentially useful.

We have deliberately chosen to limit this publication to only include officially manufactured mechanisms that can be used as boobytraps or for sabotage. This excludes many mine and grenade fuzes, but does include those that can be used in a stand-alone mode as initiating devices for explosive charges. We will not, however, attempt to describe any improvised devices or methods. The items are not presented in chronological order but are instead presented in an alpha numeric sequence to make them easier to find.

It is appropriate here to discuss some history. This was an interesting project, since the Former Yugoslavia (FRY) was never truly a single entity with its mix of cultures, religions, and languages. Some of this is evident in the firing devices found in this document. For example, Croats in the FRY utilized the Latin alphabet, while Serbs used Cyrillic lettering to mark their ordnance although the firing devices are virtually the same. Many of the devices in this publication originated in the FRY, but have continued to be manufactured in either Croatia, Serbia, or even Bosnia-Herzegovina after the breakup. Those firing devices with a nomenclature only designated in the Latin alphabet were supposedly only manufactured in Croatia.

It should be noted that the photos are certainly not all ours. We have been collecting images from other ordnance consultants and collectors, museums and off the internet for years and as a result of poor record keeping in many cases, we have no idea where we found some of them. Where known, we have acknowledged contributors in the credits page. If you find one of your photos in here and your name is not in the credits, please accept our apologies for using it without permission.

This series is not simply our effort; many people have contributed to its completion, have read it over, offered corrections and pointed out blatant errors. You know who you are and our thanks for your help. If you happen to find one of those errors, please let us know so it can be corrected. Likewise, if you have any additional information or images that you would like to share, please let us know so that we can include that information in any potential future updates.

Alexandria, VA
1 March 2026

YUGOSLAV (CROATIAN) ACRONYMS

EMU = Elektromehanicki Upaljac = Electromechanical Igniter
SU-10 = Satni Upaljac, Desetocasovni = Clock Igniter, Ten Hour
SU-24 = Satni Upaljac, Dvadeset Cetvorocasovni = Clock Igniter, Twenty-four Hour
UDOd = Upaljac Diverzantski Odvijajuci = Igniter Diversionary Unscrewing
UDOP = Upaljac Diverzantski Otpusno-Potezni = Igniter Diversionary Pressure-Release
UDP = Upaljac Diverzantski Potezni = Igniter Diversionary Pull
UDU = Upaljac Diverzantski Univerzalni = Igniter Diversionary Universal
UDVK = Upaljac Diverzantski Vremenski s Kiselinom = Igniter Diversionary Delay with Acid
UDZ = Upaljac Diverzantski Zglobni = Igniter Diversionary Articulated
UMNOP = Upaljac Mehanicki Nagazano Otpusno-Potezni = Igniter Mechanically Stepped Pressure-Release
UMNP = Upaljac Mehanicki Nagazano Potezni = Igniter Mechanically Stepped Pull
UMOP = Upaljac Mehanicki Otpusno-Potezni = Igniter Mechanical Pressure-Release
UMP = Upaljac Mehanicki Potezni = Igniter Mechanical Pull

INDEX

Designation	Type	Page
EMU-1	Pressure/Pull	8
LAM-1 and LAM-2	Laser	9
SU-10Ch	Delay	11
SU-24Ch M.70	Delay	13
SU-24Ch M.83	Delay	14
UDB-1	Tilt	15
UDOd-1	Anti-withdrawal	16
UDOP-1	Pressure-Release	18
UDP-1	Pull	19
UDU and UDU-1	Multifunction	20
UDVK	Delay	21
UDZ-1	Pressure/Pull	23
UEPZh	Breakwire	24
UMNOP-1	Multifunction	26
UMNP-1	Pressure/Pull	29
UMOP-1	Pressure-Release/Pull	32
UMP-1	Pull	34
UMP-2	Pull	35
UPM-1	Pressure/Pull	37
UPM-2	Pull	38
UPMNP-1	Pull	39
UPP	Pressure-Release	40
USA-T	Acoustic	41
USD-T	Inertia/Tilt	42
USD-T	Multifunction	44
USE-T	Delay	46
USHNP-1	Pressure-Release/Pull	48
USHP-1	Pull	49
USHT	Pull	50
USHT-1	Delay	51
USHTZ-1	Delay	52
USI-T	Inertia/Tilt	53
USKhT-1	Delay	55
USS-T	Photoelectric	56
UST-T	Thermal	58
USV-T	Vibration	60
U-TE	Delay	61
UV-24	Training	62
Manufacturers		64
Credits/References		65

YUGO MINE/BOOBY TRAP SWITCHES/FUZES No. 1

© 1997 R. & S. Gravett
Stables Flat
Wilson House, Wilton
Salisbury SP2 0B3
Tel: 01722 744061

R. & S. Gravett
Stables Flat
Wilson House, Wilton
Salisbury SP2 0B3
Tel: 01722 744061 © 1997

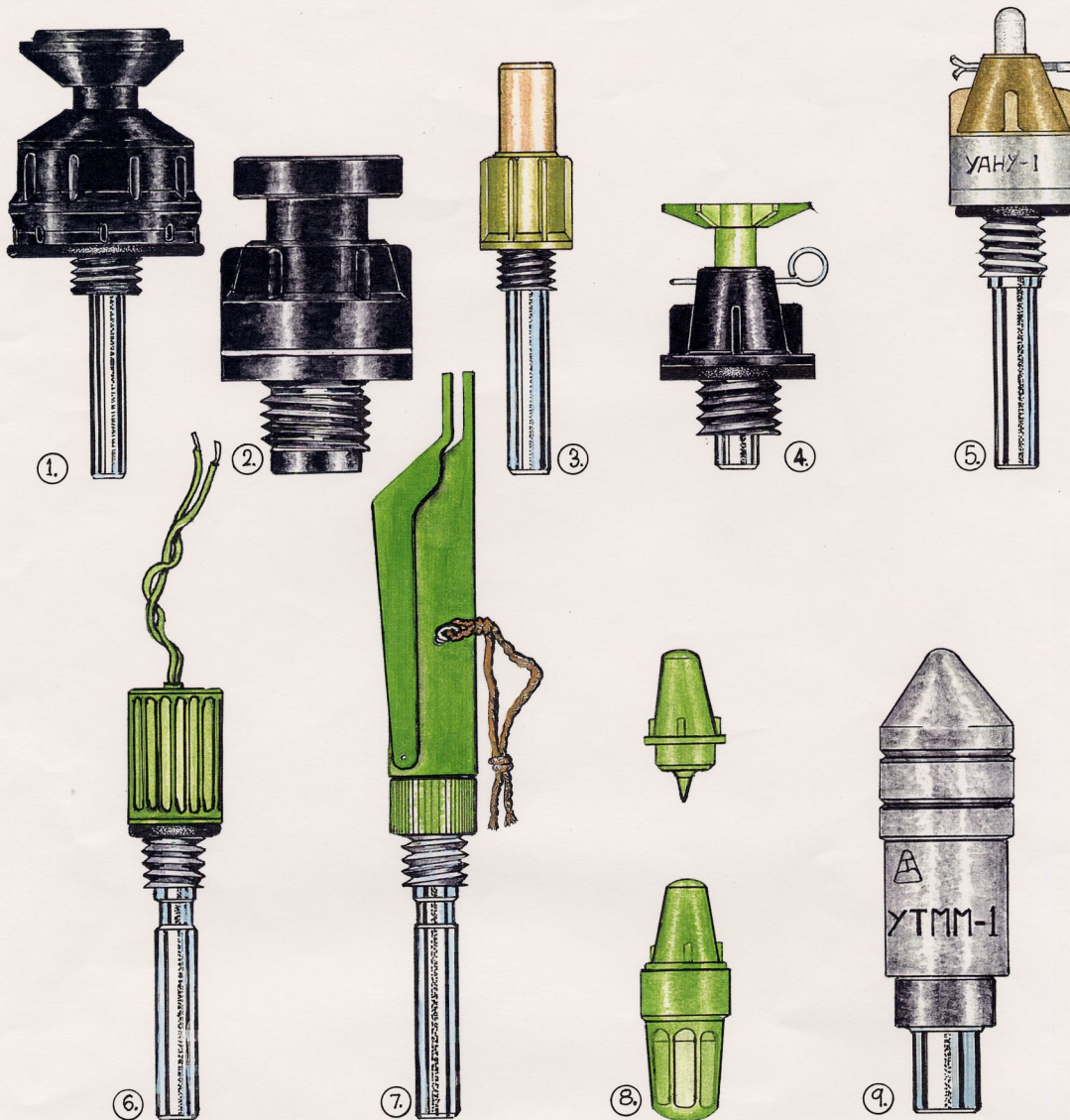

① UTMAH-3

PLASTIC, PRESSURE, FRICTION
FUZE FOR TMA-3

② UTMAH-4

PLASTIC, PRESSURE, FRICTION
FUZE FOR TMA-4

③ UPMAH-1

PLASTIC, PRESSURE, FRICTION
FUZE FOR PMA-1

⑤ UANU-1/UTMAH-1

PLASTIC, PRESSURE, FRICTION
FUZE FOR TMA-2, TMA-1, TMA-5

④ UPMAH-2

PLASTIC, PRESSURE, FRICTION
FUZE FOR PMA-2

⑥ EK-40-69

ELECTRIC DETONATOR
FOR MRUD

⑦ UDOP-1

METAL, PULL, PRESSURE
RELEASE FUZE

⑧ UPMAH-3

PLASTIC, PRESSURE, FRICTION
FUZE FOR PMA-3

⑨ UTMM-1

METAL, PRESSURE, PERCUSSION
FUZE FOR TMM-1

R. & S. Gravett
Stables Flat
Wilson House, Wilton
Salisbury SP2 0B3
Tel: 01722 744061 © 1997

© 1997 R. & S. Gravett
Stables Flat
Wilson House, Wilton
Salisbury SP2 0B3
Tel: 01722 744061

YUGO MINE/BOOBY TRAP SWITCHES/FUZES No.2

R. & S. Gravett
Stables Flat
Wilton House, Wilton
Salisbury SP2 0BJ
Tel: 01722 744061
© 1997

UMNOP-1
METAL AXIAL, RADIAL PULL
PRESSURE, PRESSURE RELEASE
PERCUSSION FUZE

MUV
PLASTIC OR METAL, PULL
TENSION RELEASE PERCUSSION
FUZE - SOVIET COPIES

UMNP-IV
METAL, PULL/PRESSURE
PERCUSSION FUZE

UMP-1
METAL, PULL/TENSION
RELEASE PERCUSSION
FUZE - PMR-1, PMR-2

UMOP-IV
METAL, PRESSURE
RELEASE FUZE

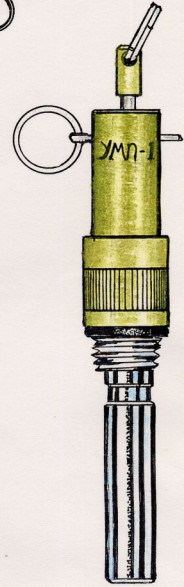
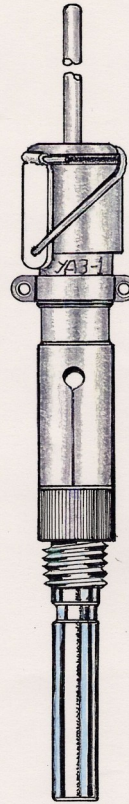
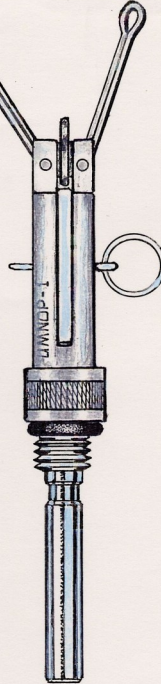
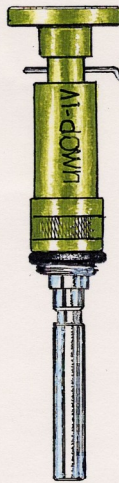

UDZ-1

METAL, PULL/PRESSURE RELEASE
PERCUSSION FUZE

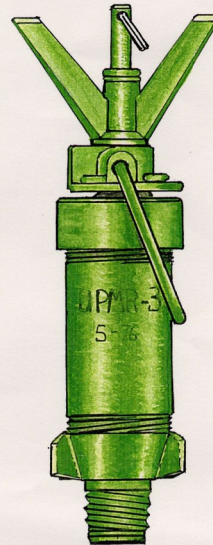
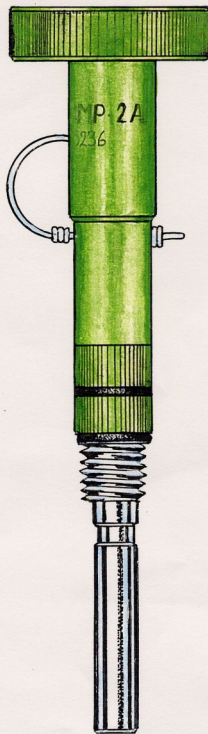
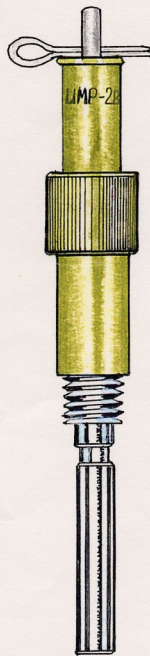

UMP-2V

METAL, AXIAL PULL
PERCUSSION FUZE

UPMR-2AS

METAL, PULL, PERCUSSION
FUZE WITH FLARE FOR PMR-2

UPMR-2A

METAL, PULL, PERCUSSION
FUZE FOR PMR-2

UPMR-3/UPROM-1

METAL, PULL-PRESSURE, PERCUSSION
FUZE FOR PMR-3, PROM-1

UDVK

CRUSH, CHEMICAL DELAY
FUZE - METAL

R. & S. Gravett
Stables Flat
Wilton House, Wilton
Salisbury SP2 0BJ
Tel: 01722 744061
© 1997

R. & S. Gravett
Stables Flat
Wilton House, Wilton
Salisbury SP2 0BJ
Tel: 01722 744061
© 1997

EMU-1

Type – Pressure/Pull

Height – 6.6-7.2 in. (168-182 mm)

Diameter – 4.2 in. (107 mm)

The EMU-1 is an electromechanical firing device originally intended for use against trains and railway lines; it can however, be employed against other targets. It is initiated by pressure or pull.

The firing device consists of an alloy body; a central spigot assembly containing a vertical pressure rod with safety clip, a lamp holder with translucent cover; and an insulated pair of firing leads protruding from the main body. The two sections of the firing device can be unscrewed, allowing a 4.5V battery to be inserted into the lower body.



*EMU-1 Firing Device
Image – MTM*

For use, the two sections of the body are unscrewed and a battery installed. In the pressure mode, the device is emplaced under a rail track and concealed. The firing leads are connected to a detonator in an explosive charge and camouflaged. The safety is removed arming the mechanism. When a train passes over the track it is pushed down slightly putting pressure on the rod. The rod moves downward closing a circuit and allowing the battery to initiate the electric detonator and charge.



If utilized as a boobytrap – it can be emplaced in a location where vehicle or foot traffic is expected. A small piece of wood placed on top of the vertical rod serves as a pressure plate.

In the pull, or tripwire, mode, the firing device is emplaced with the safety device in place. A weight placed on top of the vertical rod applies pressure. A tripwire is attached to the safety device. When the tripwire is pulled, the safety device is removed, and the weight on the rod closes the firing circuit initiating the attached electric detonator and explosive charge.

The body of the EMU-1 firing device is painted an olive green, with the designation embossed on the bottom of the device.

LAM-1 and LAM-2



LAM-1 Firing Device

Type – Laser

Weight – 3.9 lbs. (1.8 kg) (LAM-1 receiver), 4.4 lbs. (2.0 kg) (LAM-2 receiver)

Length – 8.5 in. (216 mm) (LAM-1 and LAM-2 receivers)

Width – 2.7 in. (71 mm) (LAM-1 and LAM-2 receivers)

Height – 3.5 in. (89 mm) (LAM-1 and LAM-2 receivers)

Range - 1640 yds. (1500 m) (LAM-1 receiver), 5468 yds. (5000 m) (LAM-2 receiver)

Transmitter beam width at 1093 yds. (1000 m) - 4.3 yds. (4 m)

Transmitter optical sight magnification - 4x

The LAM-1 and LAM-2 are two-component, laser-activated firing devices, consisting of a transmitter and a receiver. The devices are initiated by coded laser beams not visible to the naked eye. The range of the LAM-1 is 1,500m, and the LAM-2 is 5,000m. They can be found with either external or internal batteries. Both devices utilize the same transmitter, the difference is in the configuration of the receivers. These firing devices were likely produced in limited numbers, as there have been no credible reports of their actual use.



LAM-1 Receiver

Both the firing device kits consist of a laser transmitter and four laser receivers. The receivers utilize a 9V battery as a power source to initiate an electric detonator. Assuming a fully charged battery, the receivers can remain active for approximately 20 hours. An external



LAM-2 Receiver

power supply can be utilized to keep the receivers active beyond 20 hours.

To use either of the firing devices, the receivers are attached to explosive charges via an electric detonator. The receivers, with attached explosive charges, are emplaced and camouflaged, ensuring that there are no obstructions between the receivers and transmitter.

To initiate the explosive charges, the number of the transmitter is selected (1-4), and the transmitter aimed at the receiver. The transmitter must be aimed inside the circular reticule of the receiver's optical sight. When the trigger is pressed, the laser transmitter is activated and sends a coded package of impulses toward the receiver. It is reported that the system range can be extended to 15km in perfect atmospheric conditions.

SU-10Ch-M.66 and SU-10Ch-M.66/1

Type – Delay

Weight - 13.5 oz. (385 g)

Length – SU-10Ch/M.66 - 5.7 in. (145 mm)

SU-10Ch/M.66/1 - 4.2 in. (109 mm)

Diameter – 2.9 in. (75 mm)

The SU-10Ch series are clockwork delay firing devices designed for demolition and sabotage operations. The time delay can be set to function at five-minute intervals, up to a maximum of ten hours. They are sealed and can be used up to 60 meters underwater.

The SU-10Ch consists of a plastic outer body, with internal plastic and metal components, including a clockwork mechanism with winding key.

To use the firing device, unscrew the plastic cover, and set the desired delay time. Wind the clockwork mechanism and attach a detonator assembly. Insert the device into an explosive charge and camouflage. The final step is to press down on the arming key to initiate the timer and replace the cover.

Upon expiration of the delay time, an internal lever is tripped releasing the firing pin into the attached detonator, initiating the explosive charge.

The bodies of both the SU-10Ch-M.66 and SU-10Ch-M.66/1 firing devices are olive green. They differ only in their external configuration and dimensions. Both firing devices normally have the designation stenciled in Croatian Latin on the side or cover of the device.



SU-10Ch-M.66 Firing Device



SU-10Ch-M.66/1 Firing Device

SU-10c, M66/1 MECHANICAL 10hrs TIME DELAY SWITCH - YUGO

GENERAL DESCRIPTION

The SU-10c M66/1 is a mechanical clockwork fuse designed for demolitions and sabotage work. The fuse is made from high impact phenolic plastic similar to its larger cousin, the SU-24c M70. The internal mechanism is a basic 10 hour clockwork mechanism that releases a 'cocked' striker. This functions the M66 percussion detonator assembly after a preset delay time. The mechanism can be set to function at five minute intervals, up to a maximum delay time of ten hours.

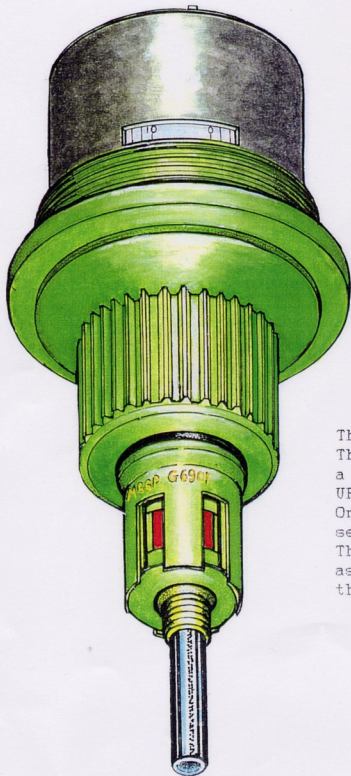

GENERAL VIEW OF THE FUSE WITHOUT CAP

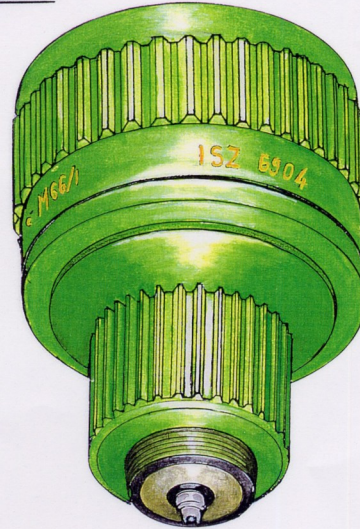
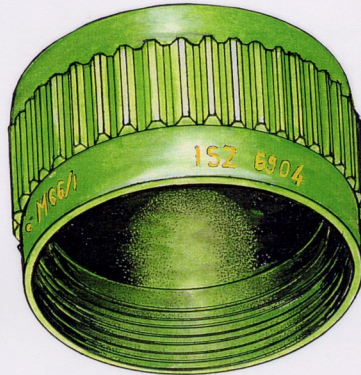

GENERAL VIEW OF THE SU-10c M66/1

The top cover of the fuse is unscrewed to reveal the fuse controls. These controls consist of:- a clockwork 'Winder' hole marked - NAVIJANJE, a 'Time Set' key marked - TEMPIRANJE and a 'clock run' switch marked - UPUCENO. On the side of the control cover is a window through which the time delay setting can be seen. The base of the SU-10c has a small threaded spigot that the M66 detonator assembly screws on to. As with nearly all Yugoslavian fuses, the fuse thread is an M10x1, allowing it to be compatible with all explosive stores.

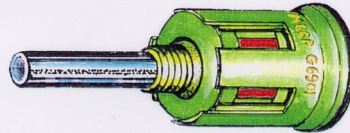

M66 DETONATOR ASSEMBLY

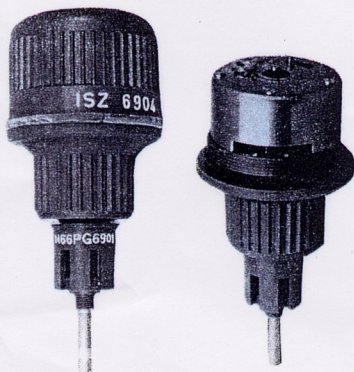

PHOTOGRAPH OF THE FUSE

COMPONENTS

- 1.- Clockwork Winder.
- 2.- Time Setting Window.
- 3.- Clock Run Switch.
- 4.- Clock Stop Position.
- 5.- Time Set key.
- 6.- M66/1 Det Assembly.

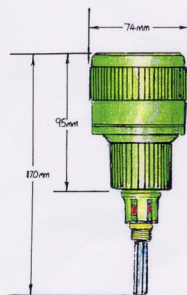

DIMENSIONS OF THE FUSE

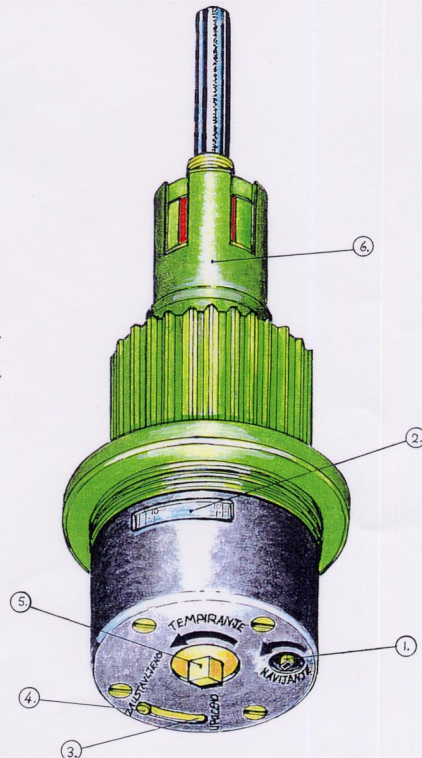

CONTROLS ON THE TOP OF THE SU-10c

The SU-10c M66/P1 is a variant of this fuse and is designed for use with the M-71 Limpet mine. The clockwork mechanism is the same as the SU-10c M66/1 but the body casing and waterproofing is different to ensure reliable underwater usage.

SU-24Ch-M.70

Type – Delay

Weight - 11.2 oz. (320 g)

Diameter – 3.9 in. (99 mm)

Height – 1.8 in. (45.7 mm)

The SU-24Ch is a clockwork delay firing device designed for demolition and sabotage operations. The time delay ranges from 15 minutes to 26 hours.

The firing device consists of a plastic outer body, with internal plastic and metal components, that includes a clockwork mechanism with winding key, a brake mechanism, and a safety pin. A receptacle in the lower body will accommodate either a nonelectric detonator, or an electrical detonator adaptor with attached firing leads.



SU-24Ch-M.70 Firing Device

To use the firing device, the two sections of the body are unscrewed. Utilizing the enclosed winding key, wind the clockwork mechanism and remove the key. Rotate the faceplate of the clockwork mechanism clockwise to the desired delay time. Screw a nonelectric detonator into the receptacle in the lower body and insert into an explosive charge. Alternatively, an electrical adaptor can be screwed into the receptacle, and the leads of the adaptor connected to a power source and an electric detonator. Camouflage the firing device and explosive charge. The final step is to remove the safety pin and screw the cover of the SU-24Ch back onto the body. The firing device is now armed.

Upon expiration of the delay time, an internal lever trips releasing the firing pin into the nonelectric detonator initiating the explosive charge. If the electrical detonator adaptor was used, the firing pin completes an electrical circuit.



A training version of the SU-24Ch-M.70 was also produced and designated VSU-24Ch. The bodies of the SU-24Ch and VSU-24Ch firing devices are olive green, with the VSU-24CH having a light green band across the top of the cover. The firing device designation is stenciled in Croatian Latin on the top of the device. The Serbian term “Vežbovni” translates as “Exercise.”

VSU-24Ch Firing Device Trainer
G. Zahaczewsky

SU-24Ch-M.83

Type – Delay

Diameter – 2.7 in. (70 mm)

Height – 3.4 in. (87 mm)

The SU-24Ch-M.83 is a clockwork delay firing device designed for demolition and sabotage operations. The time delay ranges from 15 minutes to 24 hours.

The firing device consists of a plastic outer body, with internal plastic and metal components, including a clockwork mechanism.

To use the firing device, unscrew the top and remove it. Turn the time setting ring in the direction of the arrow until the desired delay is reached then replace the top. Screw a nonelectric detonator set into the receptacle in the lower body and insert it into an explosive charge. Emplace the charge and camouflage it.

An internally threaded brass fitting allows attachment to grenades or the secondary fuze wells of landmines, such as the TMA-1, TMA-1A, TMA-2, TMA-2A, or TMA-5.



SU-24Ch-M.83 Firing Device

Upon expiration of the delay time, an internal lever trips and releases the firing pin into the attached nonelectric detonator and initiates the explosive charge.

The body of the SU-24Ch-M.83 firing device is olive green. The firing device designation is stenciled in Croatian Latin on the top of the device.



SU-24Ch-M.83 Firing Device

UDB-1

Type – Tilt

The UDB-1 is a tilt firing device used to close an electrical circuit in boobytrap applications.

The fuze body is plastic containing a metal ball, safety pin, two threaded screws constituting the electric contact switch, and two external attachment points. The firing device requires a minimum 4.5-volt AC or DC power source.

For use: test the device by moving it back and forth to ensure that the metal ball moves freely. The device is emplaced with the ball at the opposite end from the electrical contacts. If possible, the device resistance should be checked with an ohm meter to ensure the ball is not touching the contacts. The leads are then attached from the device to an electrical detonator and inserted in an explosive charge. Once the device and charge are camouflaged the safety pin can be removed, arming the trap. When the device is tilted, the ball rolls down the tube until it touches the two electrical contacts, closing the circuit and initiating the attached explosive charge.

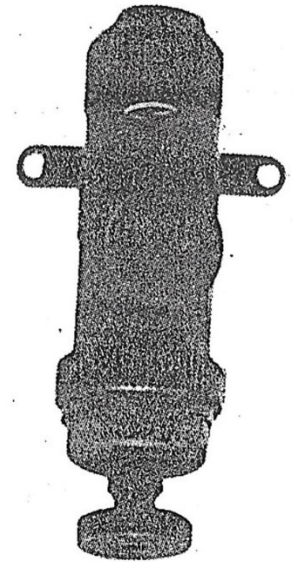

UDB-1 Firing Device

If the UDB-1 is used in the pull mode, the device is emplaced so that the ball will fall or roll downward if the safety pin is removed. A tripwire is attached to the safety pin and anchored. When the tripwire pulls the safety pin, the ball rolls down until it touches the electrical contacts closing the circuit initiating the attached explosive charge.

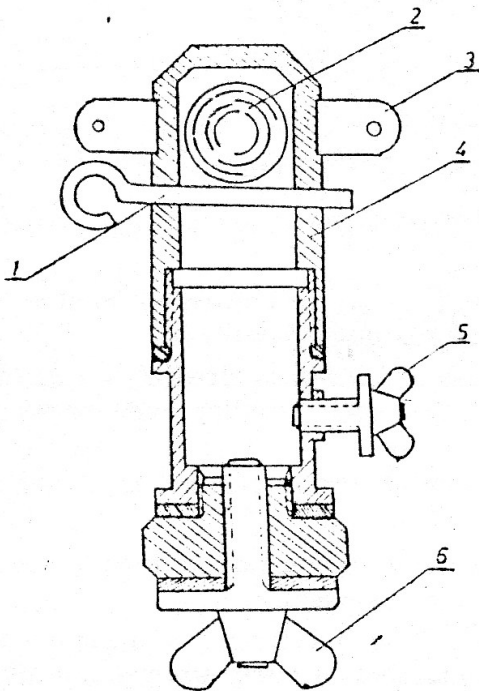

UDB-1
1- Safety Pin, 2- Contact ball,
3- Mounting bracket, 4- Body,
5- side contact, 6- bottom contact.

UDOd-1

Type – Anti-withdrawal
Weight - 2.3 oz. (66 g)
Length – 2.1 in. (55 mm)
Diameter – 0.9 in. (25 mm)

The UDOd-1 is a mechanical firing device that Yugoslavian manuals describe as an “unscrewing fuze.” The device can be used to create an anti-removal feature in a variety of items. The device is initiated when an attempt is made to unscrew the item in a counterclockwise direction.

There are several variations of this device the most common having a two-piece body constructed of brass. The upper part of the body consists of a threaded end cap whose diameter, in some models, can be adjusted using grub screws. The cap is screwed onto and holds the striker assembly in a cocked firing position. The lower part of the firing device contains the spring-loaded striker assembly and has protruding flanges that prevent the device from turning when in place. (Note that there are versions that have three rings machined around the body in lieu of the flanges.) The device is threaded for the M67 detonator assembly, although it can accept a threaded safety fuze adapter. A cork block is provided with each firing device to allow it to be properly secured when emplaced.



UDOd-1 Firing Device



UDOd-1 Firing Device

For use the end cap of the device is attached to the item to be boobytrapped (e.g., the inside of a vehicle fuel filler cap) that requires unscrewing to remove. The firing device body is then passed through the cork block and twisted so that the flanges (or rings) grip into the block. An M67 detonator assembly (or a safety fuze adapter with a length of fuze and detonator attached) is then screwed into the bottom of the firing device. The cork block is wedged into the item. The final step is to remove the safety pin. Any attempt to unscrew the boobytrapped component will cause the end cap to also unscrew releasing the cocked striker into the percussion cap of the detonator assembly.

Other potential applications are in a thermos bottle - or canteen - with the end cap secured to the screw-on top, or secured inside a vehicle engine compartment so that the drive belt or fly wheel unscrews the end cap of the firing device, thereby releasing the cocked striker assembly.

UDod-1 BOOBYTRAP SWITCH - YUGO

MG-33

R & S GRAVETT
21 WATER DITCHAMPTON
WILTSHIRE
© 1998
01722-744061

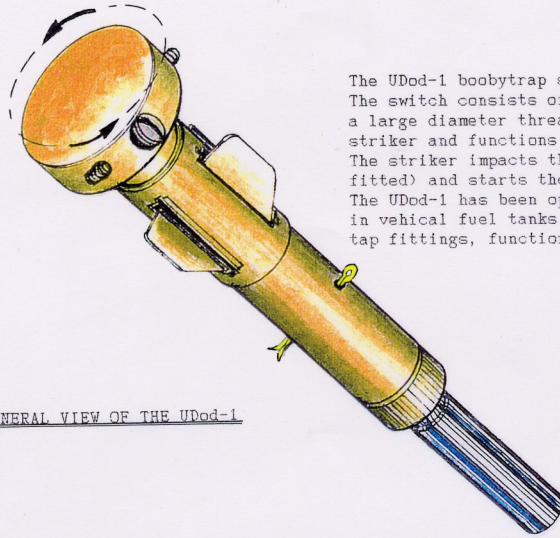

GENERAL VIEW OF THE UDod-1

A large square of cork is supplied with the switch to enable it to be fitted to almost any size opening. The body fins are designed to dig into the cork and prevent the fuse body from rotating. Two threaded screws are fitted to the circular retaining nut. These can be extended to ensure a firm fit into the aperture that is to be booby-trapped.

GENERAL

The UDod-1 boobytrap switch is a purpose made, Anti-Twist firing device. The switch consists of a 'cocked-striker' mechanism. This is restrained by a large diameter threaded nut. Unscrewing the restraining nut, releases the striker and functions the switch. The striker impacts the percussion detonator or fuse ignitor (which ever is fitted) and starts the initiation train. The UDod-1 has been operationally deployed in Bosnia and was found fitted in vehical fuel tanks, (where the cap required unscrewing) and inside water tap fittings, functioning when the tap was turned on.

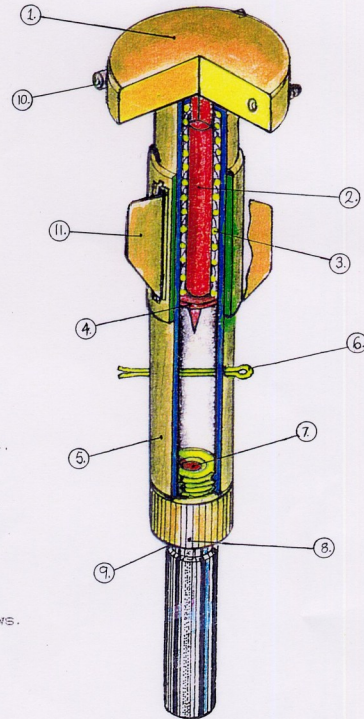

SECTIONED VIEW OF THE SWITCH

COMPONENTS

- 1.- Circular Restraining Nut.
- 2.- Striker.
- 3.- Striker Spring.
- 4.- Striker Pressure Washer.
- 5.- Fuse Body.
- 6.- Safety Pin.
- 7.- Percussion Cap.
- 8.- Detonator Assembly.
- 9.- M10x1 Thread.
- 10.- Adjustable fitting screws.
- 11.- Body fins.

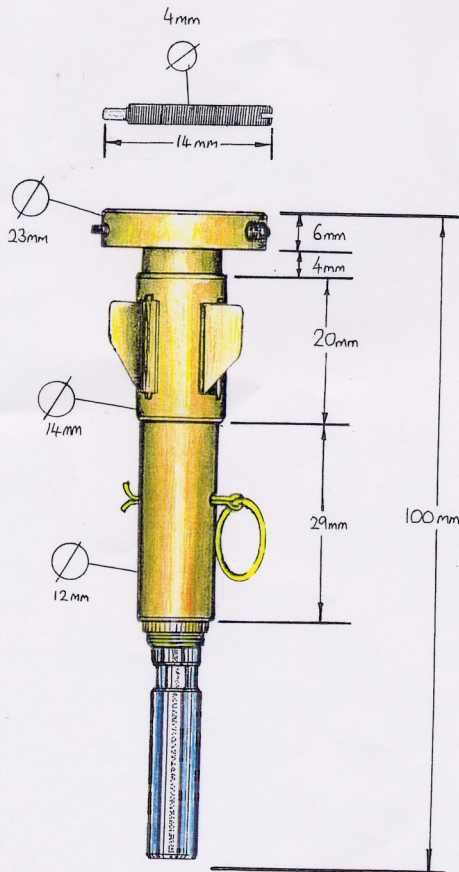

DIMENSIONS OF THE SWITCH

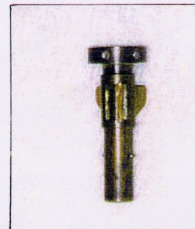

PHOTOGRAPH OF

UDod-1

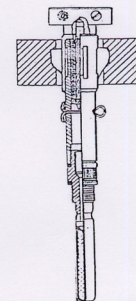

CORK FITTED TO UDod-1

R & S GRAVETT
21 WATER DITCHAMPTON
WILTSHIRE
© 1998
01722-744061

UDOP-1

Type – Pressure-Release
Length – 3.3 in. (86 mm)
Width – 0.6 in. (15 mm)
Height – 0.7 in. (18 mm)

The UDOP-1 is a simple mechanically operated, pressure release firing device directly copied from the British No. 6 Mk. 1 release switch, which was provided to the Yugoslavian resistance by the British SOE during the Second World War. It is used with explosive charges as a boobytrap or could be used as an anti-lift device for mines.



UDOP-1 Firing Device

The firing device is rectangular in shape and is made from an aluminum alloy. It has a hinged lid mounted on top of the body. The firing device body contains a cocked-striker assembly retained by a sear held in place by the hinged lid of the device. A safety pin positioned midway along the firing device body passes through a hole in the striker to prevent any movement during storage and shipment. The square end of the device is internally threaded to accept an M67 detonator assembly.

To use the firing device, it is attached to an explosive charge. A weight is placed on the hinged lid, which places pressure on the sear and frees up the safety pin. If the safety pin can be withdrawn easily, the switch has been correctly set. If the pin is not free to move, there is insufficient weight on the lid. Once emplaced, both the firing device and attached explosive charge are camouflaged prior to removing the safety pin. When the weight is removed, the firing pin spring exerts pressure on the sear which rotates forcing the lid up until the sear can lift fully. Once the sear is fully raised the firing pin is free to fly forward and strike the percussion cap initiating the explosive train.

The UDOP-1 is normally painted olive drab.

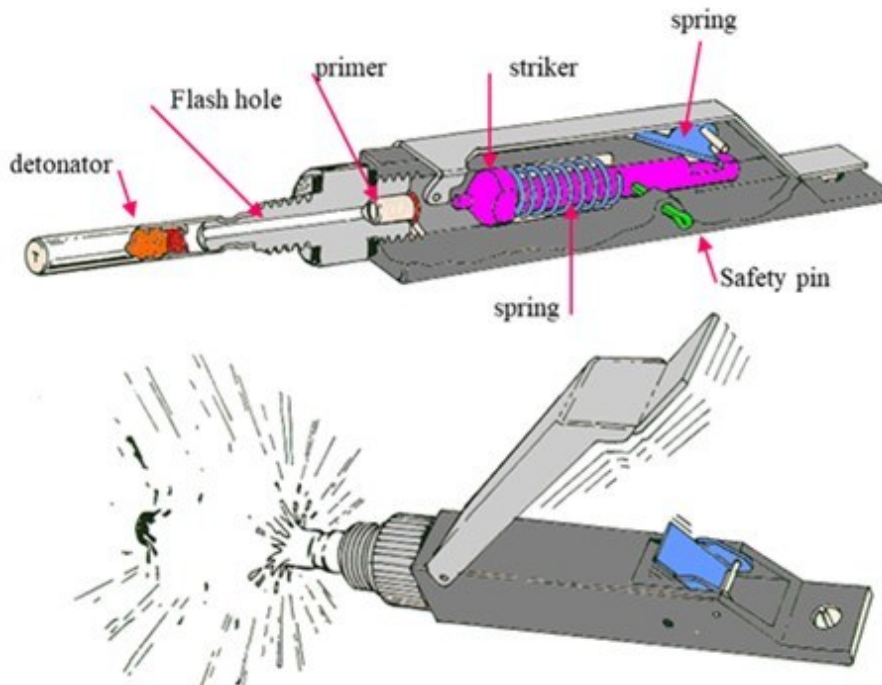

*UDOP-1 Firing Device
Image – B.Gravett*

UDP-1

Type – Pull
Length – 2.7 in. (70 mm)
Diameter – 0.4 in. (11 mm)

The UDP-1 is a direct copy of the British No. 4 Mk. 1 pull switch that was provided to the Yugoslavian resistance by the British SOE during the Second World War. It is used as a boobytrap.



UDP-1 Firing Device

The firing device has a brass cylindrical body. Two mounting eyes are attached along the body. One end of the device is threaded internally and designed to be fitted with a fuse adapter and percussion cap or the M67 detonator assembly. A ‘U’ shaped clip that holds the striker protrudes from the other end. A safety pin passes radially through the body and striker to hold it in the safe position.

To use the firing device, it is attached to an explosive charge. The ‘U’ shaped clip is cupped to fit around the rounded end of the cocked-striker assembly. The cups retain the striker because they are held in place by the body wall. A tripwire is attached to the ‘U’ shaped clip, and the charge and firing device are camouflaged. Once the safety pin is removed, a pull on the tripwire moves the clip clear of the firing device body, where the cups can move apart and release the cocked striker allowing the striker to fly forward into the percussion cap.

The UDP-1 is unpainted.

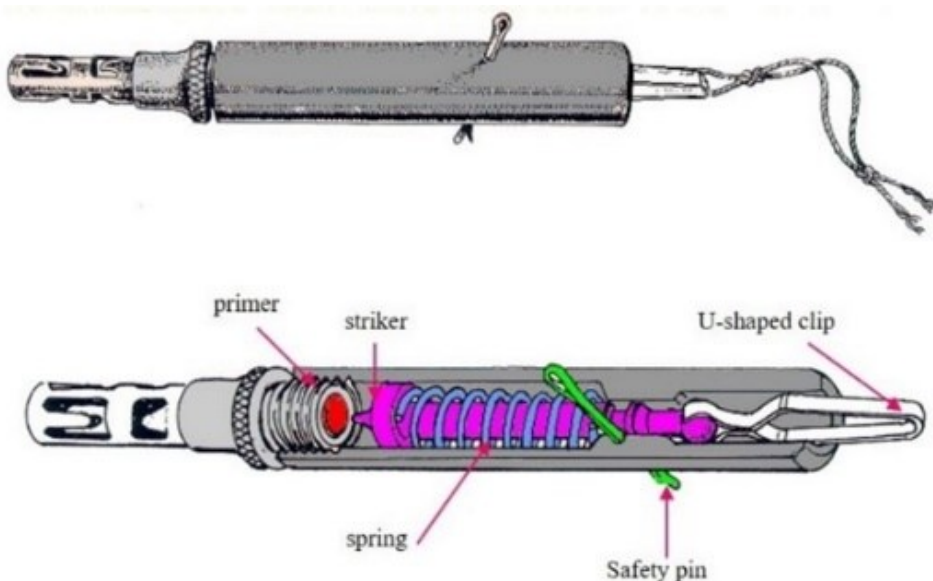

*UDP-1 Firing Device
Image – B.Gravett*

UDU and UDU-1

Type – Multifunction
Weight – 3.4 oz. (99 g)
Length – 4.4 in. (114 mm)
Width – 0.5 in. (12.7 mm)

The UDU and UDU-1 are multifunction firing devices which can function on pressure, pressure-release, or pull.

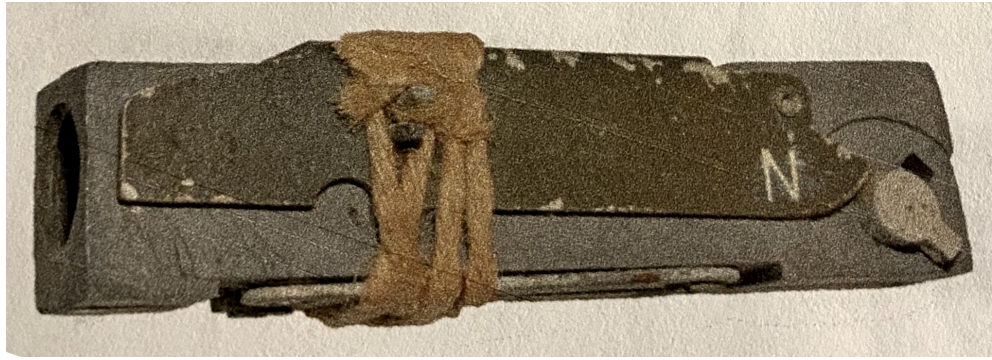

UDU Firing Device

The main body is rectangular in shape and manufactured from brass with iron fittings. It is fitted with a hinged lid on the top and two pivoting arms on the base used to secure the device to a surface. The striker assembly is made from brass. There is also a safety pin that passes through the device body. A function selector switch is transversely mounted at the rear of the device and engages directly with the rear of the striker. This selector switch is rotated to determine whether pressure, release, or pull functioning is used. The device can accept either a flash detonator/fuse adaptor or the M67 detonator assembly.

The only differences between the UDU and UDU-1 are the transition from older brass fittings to cast iron fittings and the fuse adaptor from imperial to metric.

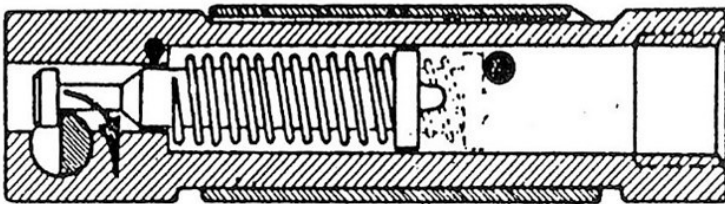
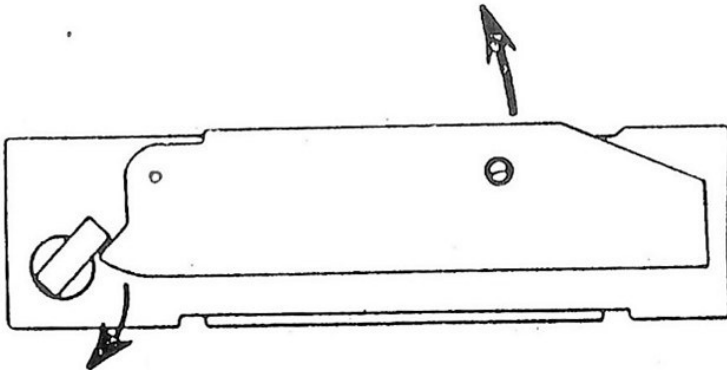
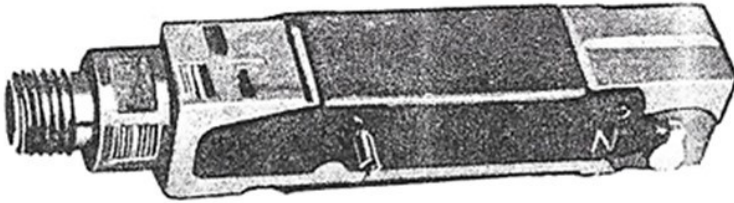

UDU Firing Device

UDVK



Type – Delay
 Length – 4.1 in. (105 mm)
 Diameter – 0.4 in. (12 mm)

UDVK Firing Device

The UDVK is a chemical time delay firing device that can trace its origins back to the British No. 10 Mk I time pencil, which was supplied to Yugoslavian Partisans during the Second World War. The delay time of the device is indicated by the color of the safety strip and is significantly affected by ambient temperature. The UDVK is not recommended for use in temperatures below 32 degrees Fahrenheit (0 Centigrade). A typical box of UDVK firing devices contains the following:

UDVK-1	Red Safety Strip	20 - 40 minutes
UDVK-2	White Safety Strip	1.3 - 3 hours
UDVK-3	Green Safety Strip	4 - 7 hours
UDVK-4	Yellow Safety Strip	9 - 13 hours
UDVK-5	Blue Safety Strip	20 - 30 hours

A card describing the delay times at different temperatures is included with each box of firing devices.

The UDVK consists of a two-part cylindrical body, the upper section being copper and the lower section of the body being tin or zinc-plated brass. The upper body contains a glass ampoule containing a corrosive liquid. The lower section contains the spring-loaded striker assembly, held in the cocked position by a wire running from the striker through the top body section to the retaining screw at the top of the body. A rectangular hole in the lower body, just above where the detonator assembly attaches accommodates a coloured safety strip that prevents the striker from reaching the detonator. A small inspection hole near the safety strip allows inspection to show if the firing device has been functioned. Older manufactured devices have a permanently attached spring clip to hold a fuse or detonator. Later manufactured devices have been modified to accept the M67 detonator assembly.

To use the firing device, the copper upper section of the firing device is crushed using pliers breaking the ampoule inside. When the ampoule is crushed, corrosive liquid flows around the striker retaining wire. The safety strip should be easy to remove, if not, the striker has already impacted the safety strip. This can be confirmed by looking through the inspection hole. The device should then be discarded. Once functioning the corrosive liquid weakens the striker retaining wire until it breaks, releasing the striker into the percussion cap of the detonator assembly or time fuse holder, which initiates the blasting cap and attached explosive charge.

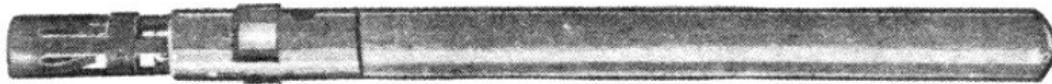

Sl. 269 – Specijalni vremenski upaljač (UDVK-1)

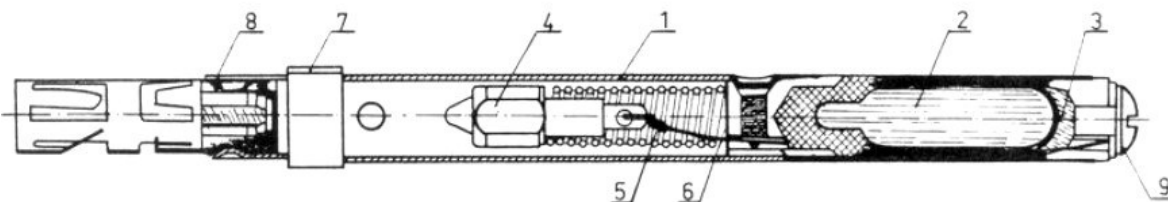

UDVK-1 Firing Device, Image – Serbian MoD

UDVK. CHEMICAL DELAY FIRING DEVICE - YUGO

R & S GRAVETT
21 WATER DITCHAMPTON
WILTON SALISBURY
WILTSHIRE
01722-744061

© 1998

GENERAL

The UDVK is a direct copy of the old British No.10 Mk.1 Chemical Time Pencil. It was designed to initiate a demolition charge or sabotage device, detonating after a set delay time. The UDVK is normally fitted with the old fashioned fuse adaptor which will accept a flash detonator or length of safety fuse. It can also be threaded to fit the M67 percussion detonator assembly. A colour coded safety bar passes through the fuse body. This prevents the striker from reaching the detonator assembly and the colour of the bar indicates the time delay. An inspection hole near the safety bar shows whether the switch has been functioned.

OPERATION OF UDVK

The fuse consists of a sprung striker that is retained by a copper wire that is anchored to a fixed anchor pin. An ampoule of acid is contained in the closed end of the fuse just above the restraining wire. The fuse is armed by removing the safety bar and crushing the rear of the fuse body. The acid leaks into the funnel and fills the copper wire cavity with the acid. The acid starts to corrode the wire until it can no longer restrain the striker. As the wire snaps, the striker is driven into the percussion cap and starts the explosive train.

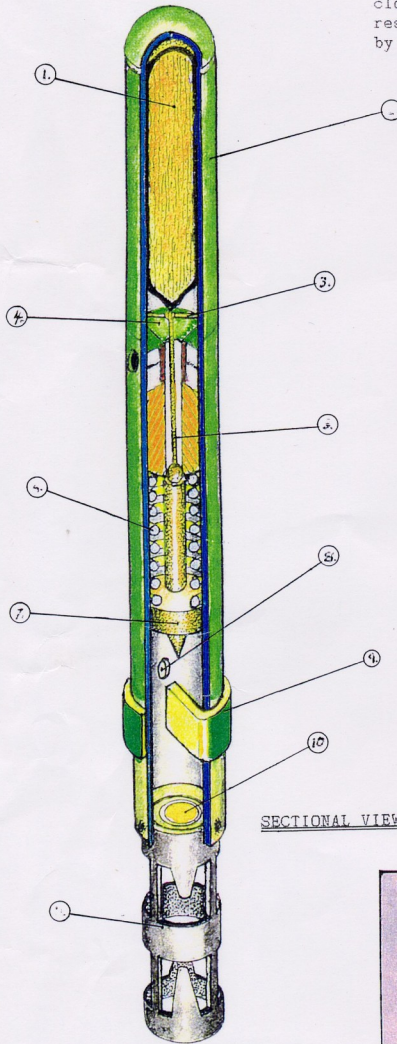

SECTIONAL VIEW OF THE UDVK

COMPONENTS

- 1.- Acid Ampoule.
- 2.- Body.
- 3.- Anchor Pin.
- 4.- Funnel.
- 5.- Restraining Wire.
- 6.- Striker Spring.
- 7.- Striker.
- 8.- Inspection Hole.
- 9.- Safety / Colour Code Bar.
- 10.- Percussion Cap.
- 11.- Fuse Adaptor.

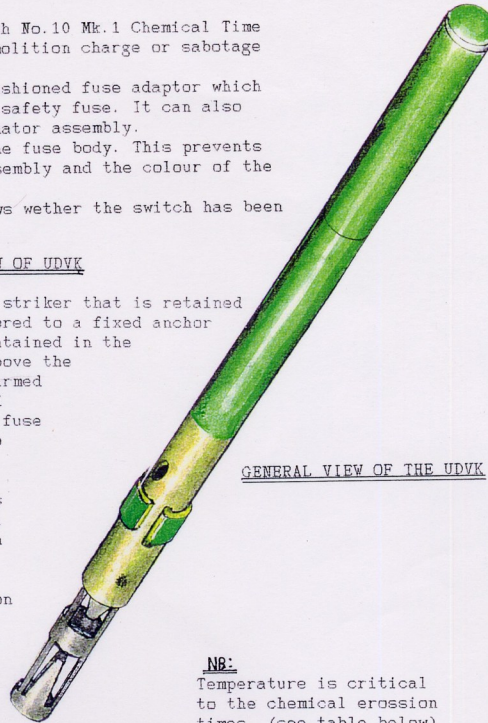

GENERAL VIEW OF THE UDVK

NR:
Temperature is critical to the chemical erosion times. (see table below)

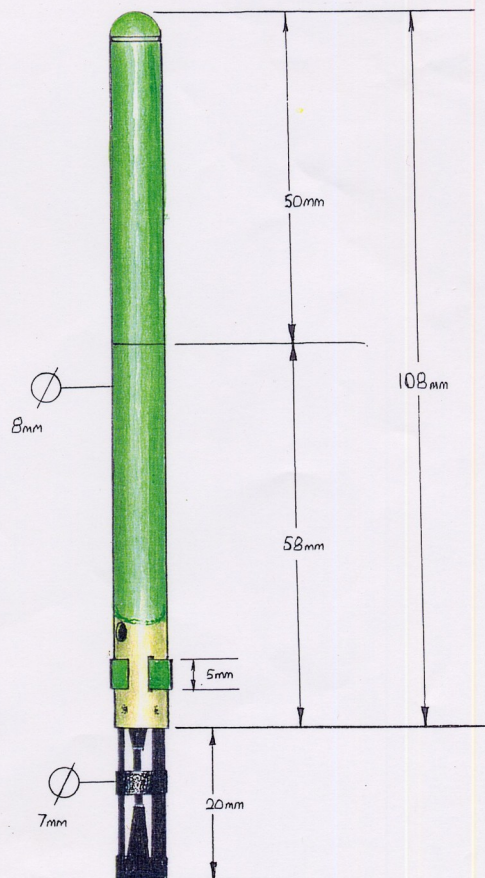

DIMENSIONS

COLOUR CODE TIMES

Temp	Red	White	Green	Yellow	Blue
-4	75m	19hr	3.25d	10d	-
14	63m	13hr	2.5d	5d	-
32	43m	5hr	16hr	28hr	-
50	31m	2.7hr	8hr	18hr	34hr
59	27m	2hr	5.75hr	12hr	24hr
68	23m	1.5hr	4hr	9hr	20hr
77	19m	1.2hr	3hr	6hr	15hr
99	12.5m	.75hr	1.5hr	3hr	6hr
109	9.5m	34m	80m	2hr	5hr

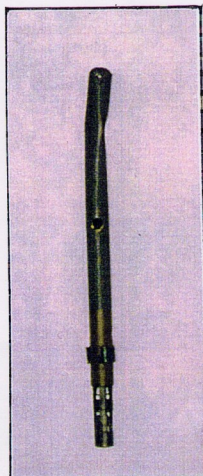

UDVK TIME PENCIL

R & S GRAVETT
21 WATER DITCHAMPTON
WILTON SALISBURY
WILTSHIRE
01722-744061

© 1998

UDZ-1

Type – Pressure/Pull

Weight – 1.3 oz. (51 g)

Length – 4.5 in. (115 mm)

Diameter – 0.7 in. (19 mm)

The UDZ-1 can be initiated by either pressure or pull on the tilt rod. It is commonly used in boobytraps but can also be used with antipersonnel mines.

Two versions of the firing device have been encountered. One consists of a brass body, while the other has a thick steel body. The body is in two sections. The upper portion contains the tilt rod assembly. The tilt rod is domed to allow easy pivoting once armed. A safety fork is present in the upper fuze body to prevent movement of the tilt rod. The safety fork travels through two grooves in the base of the tilt rod and secures the mechanism in place until removed. The lower body has a mounting bracket attached and contains a cocked striker assembly held in check by a singular retaining ball. The bottom is threaded to accept either a safety fuse holder, or the M67 detonator assembly.

For use the firing device with detonator is attached to an explosive charge. The device is secured in place and camouflaged. If tripwire operation is desired, then a wire is attached to the tilt rod and secured to an anchor point prior to removal of the safety fork. Once the safety fork is removed any movement of the tilt rod allows the cocked striker assembly to initially move upward until the retaining ball is released, at which time the striker is driven onto the percussion primer in the detonator assembly initiating the charge.



UDZ-1 Firing Device

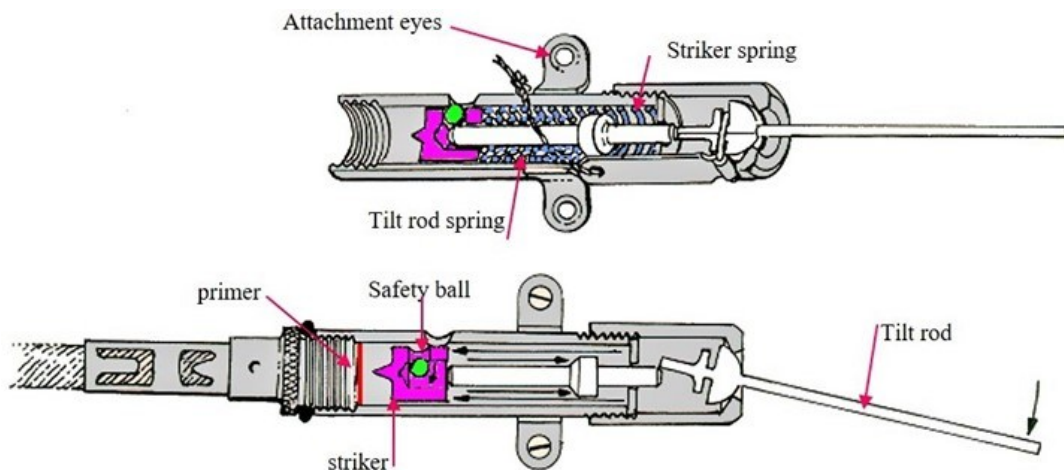

*UDZ-1 Firing Device
Image – B.Gravett*

UEPZh (УЕПЖ)

Type – Breakwire
Weight – 7.7 oz. (221 g)
(incl. battery)
Length – 3.7 in. (94 mm)
Width – 2.8 in. (73 mm)
Height – 1.4 in. (38 mm)

The UEPZh is one of a series of special electronic firing devices (also referred to as “super quick fuzes”) manufactured from 1974 by the firm Rudi Cajavec Defence Electronics of Banja Luka in the Former Yugoslavia. The device has a 20-minute arming delay. It is initiated when its breakwire is severed.

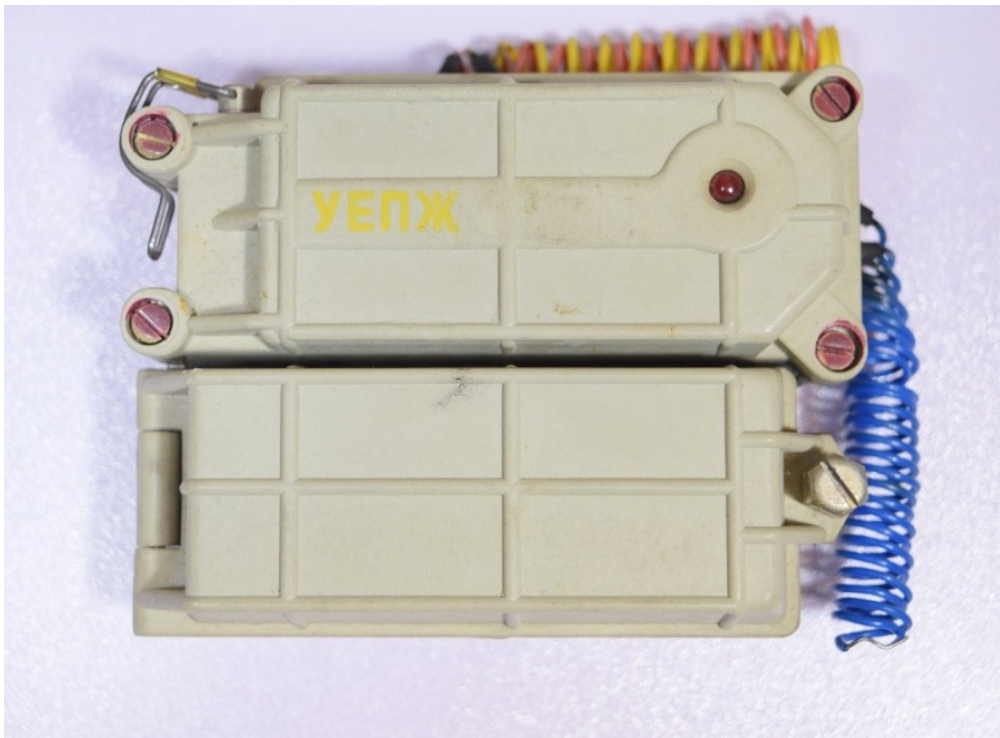

*UEPZh Special Electronic Firing Device
Photo – G. Zahaczewsky*

The firing device consists of a plastic body consisting of two compartments. One section is hinged and contains the battery (a common alkaline or lithium 9V), while the other section is sealed with a tamper indicator compound and contains the potted electronics unit with an exposed red LED. With a high quality alkaline 9V battery, the firing device has a reputed 2,500-hour life expectancy. A lithium 9V battery could almost double the life expectancy. The base of the battery compartment contains a plastic shelf that has four circles with numbers 1-12. This has no function in the UEPZh. It is commonly found in all versions of the “super quick fuzes.” The detonator/firing leads (red and yellow) extend from one side of the case. A segment of breakwire (blue) extends from another side. The safety pin is inserted in one end of the electronics compartment depressing an internal microswitch that disconnects the negative lead from the battery. A separate spool of an additional 109 yards (100m) of breakwire is provided with each firing device.

To use the firing device, the breakwire is deployed to cover the targeted area and connected to the blue leads extending from the device. A detonator is connected to the firing leads and inserted into an explosive charge. The breakwire, firing device, and explosive charge are then camouflaged. If the breakwire circuit is intact, the red LED remains off. The final step is to remove the safety pin initiating an approximate 20-minute arming delay that, upon expiration, will fully arm the firing device by charging a firing capacitor in the electronics unit. When the breakwire is broken by a minimum 6.6lb (3kg) pull it will initiate the detonator. The device may be disarmed by reinserting the safety pin depressing the microswitch disconnecting the negative battery lead, as well as discharging the firing capacitor.

The body of the firing device is unpainted, but its designation is stenciled in yellow or black. Markings may be found in either Serbian Cyrillic or Croatian Latin.



*UEPZh battery compartment
Photo – G. Zahaczewsky*

*UEPZh microswitch delay arming mechanism (which is found in all “super quick fuzes” NOTE Honeywell markings)
Photo – G. Zahaczewsky*

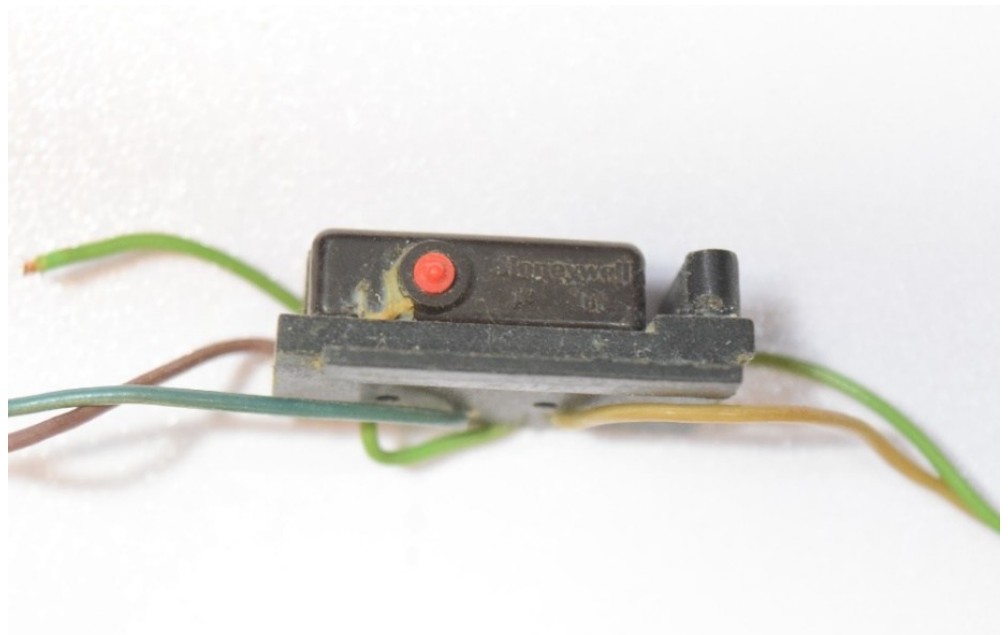

*UEPZh with packaging
Photo- Bob Leiendecker*

UMNOP-1 (YMHOII-1)

Type – Multifunction

Weight – 0.6 oz. (18 g)

Length – 3.3 in. (85 mm)

Diameter – 0.3 in. (9 mm)

The UMNOP-1 is a combination/multi-function firing device capable of being initiated by direct pressure, pressure-release, and both radial or axial pull. It is normally employed in mines but could be used with demolition charges as a boobytrap. The device is waterproof to a depth of 9.8in (25cm) and can be used under all meteorological conditions at temperatures of -30° C to +60° C. However, ice can disable the functioning of the firing device.

The device consists of a tubular metal body housing a spring-loaded striker retained directly by a radial safety pin that runs through the fuze body and striker, or by either arm of a C-shaped sear. The top arm of the sear is beveled, and the bottom arm is cut square. The sear is attached to a hinged lever normally held in place against the fuze body by an axial pin. Beneath the lever are two hinged stabilizing legs, made from split pins that keep the fuze upright when set in the pressure or pressure release modes. Nails can be driven through the loops in the legs to fix the fuze into position, or the two legs can be removed. The lower part of the body is knurled and contains an integral detonator assembly.



*UMNOP-1 and UMNOP-IV Firing Devices
Photo- Darrol Vincent Bowlzer*

To use the firing device in the pressure mode: after attaching a blasting cap and inserting the UMNOP-1 into the charge, the lockwire, and axial safety pin, are removed. The trigger lever is raised approximately 30° until it clicks into place. In this position the lower (squared) arm of the sear

engages the striker, allowing safe removal of the radial pin to arm the fuze. Once emplaced the radial safety pin is removed using a cord from a safe distance, arming the device. A pressure of just 1.3lb (0.6kg) will force the trigger lever down to release the striker onto the attached detonator

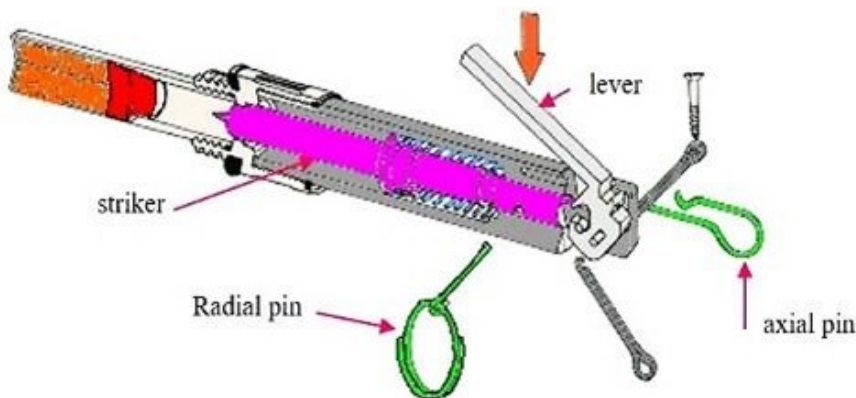

Image – B.Gravett

To operate the device in the pressure release mode, a load exceeding 1.3lbs (3.5kg) is placed on top of the trigger lever. The axial safety pin is removed, along with the lockwire securing the

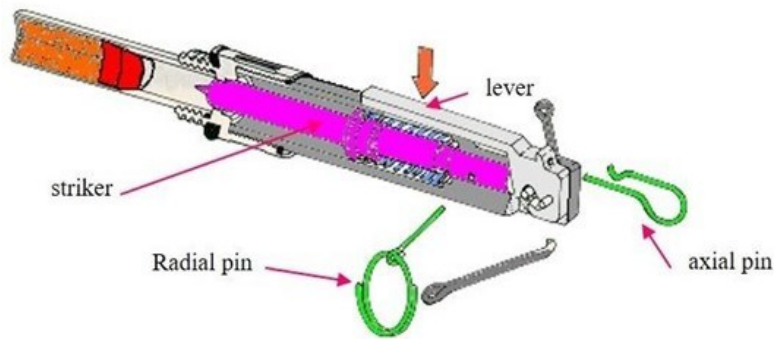

Image – B.Gravett

safety pin and anchored to a secure object. The lockwire is removed, and a string attached to the radial safety pin. From a safe distance, the string is pulled to remove the radial safety pin arming the device. When the tripwire is pulled with a force of at least 5.5lbs (2.5kg), the striker is released into the detonator initiating it along with the attached charge.

radial safety pin. A string is attached to the radial safety pin, and the components are camouflaged. From a safe area, the string is pulled to remove the radial safety pin, arming the firing device. If the load bearing weight is removed, the trigger lever will rise, releasing the striker into the attached detonator.

To use the UMNOP-1 in the axial pull mode, a tripwire is attached to the axial

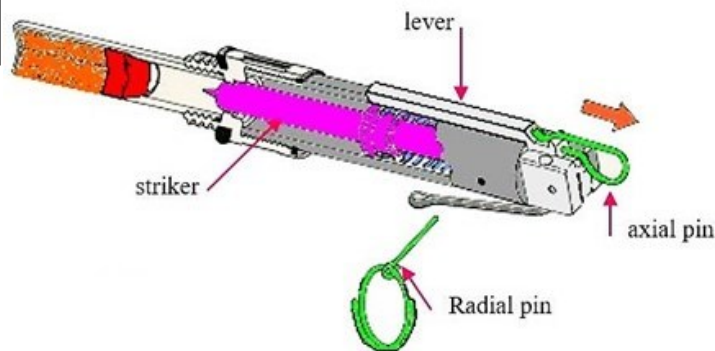

Image – B.Gravett

To use the firing device in the radial pull mode, a trip wire is attached to the radial safety pin and anchored to a secure object. The lockwire is removed, and a string attached to the axial safety pin. From a safe area, the string is pulled to remove the axial safety pin, arming the firing device. When the tripwire is pulled with a force of 3.3 to 8.8lbs (1.5 to 4kg), the striker is released into the detonator initiating it along with the attached charge.

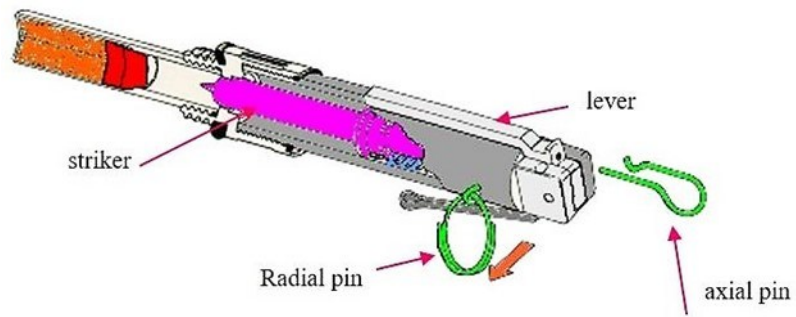

Image – B.Gravett



UMNOP-1V Practice Firing Device (partially disassembled revealing the striker), Photo – Fenix Insight

The body of the device is unpainted; however, the designation of the device is stenciled in black on the body in either Croation Latin or Serbian Cyrillic. A training version of the firing device, UMNOP-1V (the “V” in the designation stands for “Vežbovni,” which translates as “Exercise,” or “Practice”), was also produced and can be identified by a yellow band around the body, as well as the lack of an integral detonator assembly.

UMNOP-1 BOOBYTRAP SWITCH - YUGO

R & S GRAVETT
21 WATER DITCHAMPTON
WILTON SALISBURY
WILTSHIRE
© 1998
01722-744061

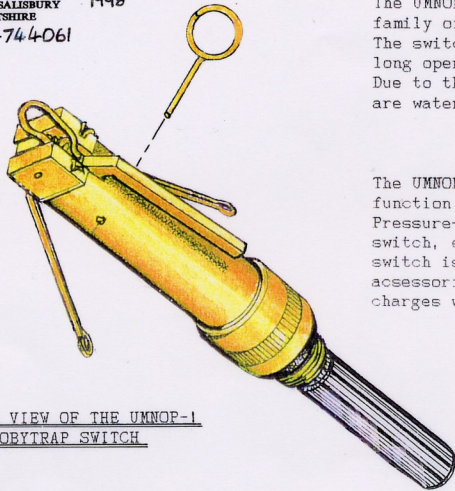

GENERAL VIEW OF THE UMNOP-1 BOOBYTRAP SWITCH

General

The UMNOP-1 Multipurpose, Mechanical boobytrap switch is a member of a family of purpose made, precision manufactured boobytrap switches. The switches are made out of a non-corrosive metal alloy which ensures a long operational deployment capability. Due to the very high standards of manufacture and assembly, the switches are waterproof and unlikely to fail.

The UMNOP-1 Switch

The UMNOP-1, is a versatile, multifunctioning switch that can be set to function in one of four modes. Axial Pull, Radial Pull, Pressure and Pressure-Release. The percussion detonator is screwed into the mouth of the switch, ensuring a watertight seal. The external connecting thread of the switch is an M10 x 1, which is common to all boobytrap and explosive accessories. Allowing this switch to be connected to baulk explosive charges with little or no preparation time.

COMPONENTS

- 1.- Axial Pull Pin / Safety Pin.
- 2.- Trigger (in pressure release position)
- 3.- Trigger pivot pin.
- 4.- Pressure-Release tooth of Trigger.
- 5.- Pressure tooth of Trigger
- 6.- Pivotted 'cotter pin' Fastener.
- 7.- Striker retaining peg.
- 8.- Radial Pull Pin / Safety Pin.
- 9.- Sealing Washer.
- 10.- Striker Spring.
- 11.- Striker Pressure Washer.
- 12.- Striker.
- 13.- Fuse Body.
- 14.- Adapter with external M10x1 thread.

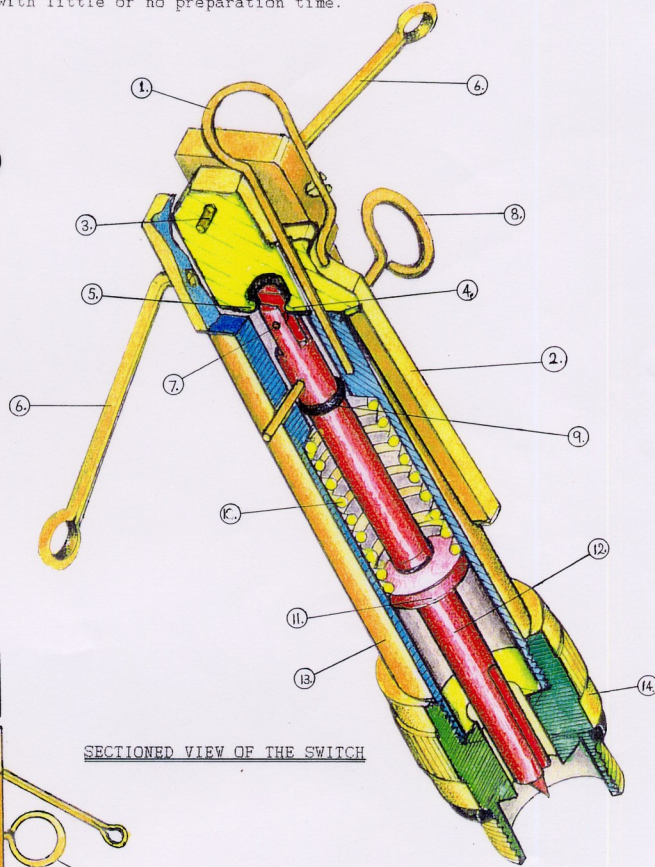

SECTIONED VIEW OF THE SWITCH

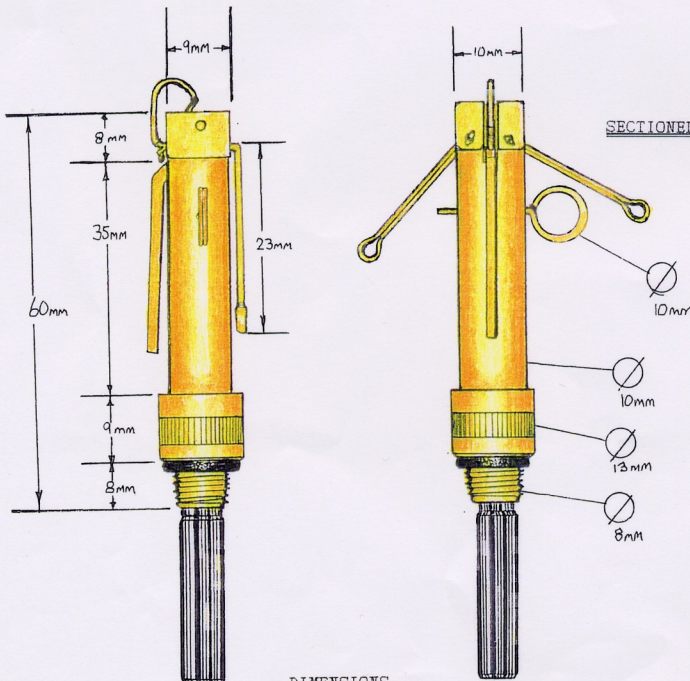

DIMENSIONS

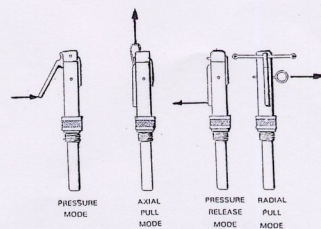

ACTION OF FORCE REQUIRED TO FUNCTION THE SWITCH

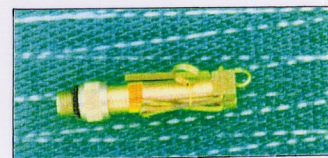

PHOTOGRAPH OF THE SWITCH

R & S GRAVETT
21 WATER DITCHAMPTON
WILTON SALISBURY
WILTSHIRE
© 1998
01722-744061

UMNP-1 (YMIII-1)

Type – Pressure/Pull
Weight – 0.5 oz. (15 g)
Length – 3.1 in. (81 mm)
Diameter – 0.4 in. (11 mm)

The UMNP-1 is a firing device initiated by either pressure or pull. It is commonly employed in mines but could be inserted into a demolition charge for boobytrap operations.

The firing device consists of a cylindrical steel body, a star-shaped spigot with a pull ring, and a radial safety pin secured by safety wire. The upper part of the device contains a hollow spring-loaded striker assembly containing an actuator rod. The striker assembly is held in check by retaining balls, which, in turn, are held in position against the walls of the fuze body by a central plug. The lower part of the body is knurled and contains a permanently attached M67 detonator assembly.

For use, the firing device is inserted into a mine, or explosive charge. One or more tripwires are attached to the pull ring. Once set and camouflaged, the safety wire and safety pin are removed.

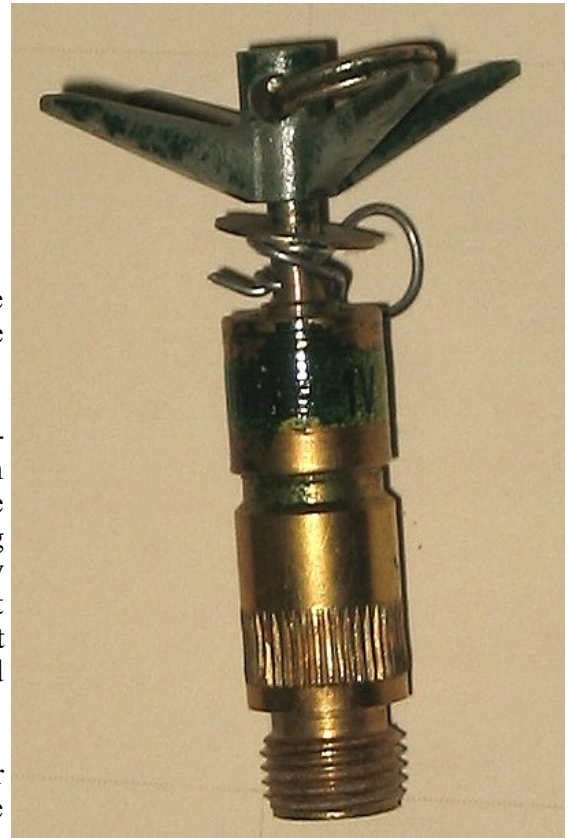

UMNP-1 Firing Device

The firing device is initiated when 8.8-15.4lbs (4-7kg) of pressure is applied directly on the star-shaped spigot, or when 4.4-15.4lbs (2-7kg) of pressure is applied to one of the tripwires attached to the metal pull ring. This creates a camming action causing the components within the striker assembly to move and release the retaining balls. Once this occurs, the striker is free to hit the percussion cap in the detonator assembly initiating the main charge.

The body of the firing device is unpainted; however, some devices can be found with the designation of the device stenciled in black in either Croation Latin or Serbian Cyrillic on the detonator assembly. A training version of the firing device, UMNP-1V (the “V” indicating the abbreviation for the term “Vežbovni,” meaning “Exercise,” or “Practice”), was also produced and is identified by a yellow band around the body, as well as the lack of an integral detonator assembly.

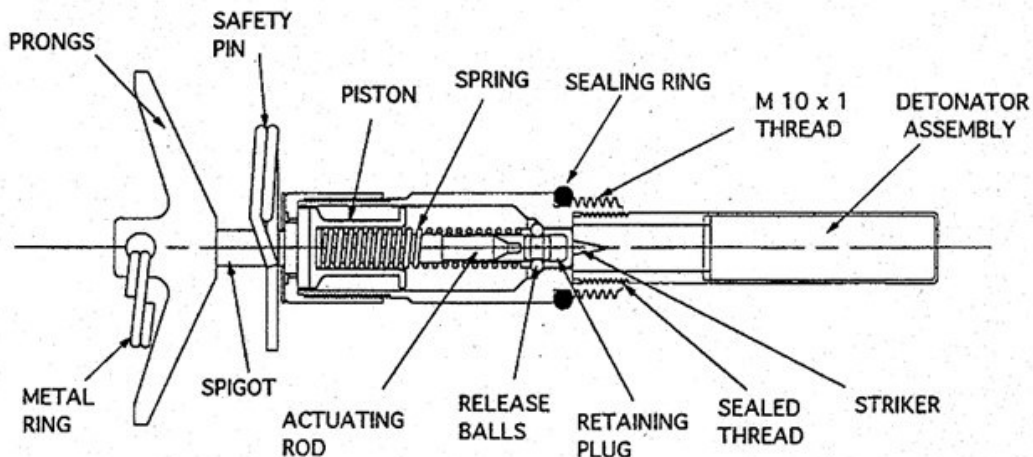

UMNP-1 Firing Device



*UMNP-1V Training Device (disassembled)
Photo – G. Zahaczewsky*

UMNP-1 BOOBYTRAP SWITCH - YUGO

R & S GRAVETT
21 WATER DICHAMPTON
WILTON SALISBURY
WILTSHIRE
1998
01722-744061

DESCRIPTION

The UMNP-1 is a booby trap switch that is designed for use with mine and demolition charges that are fitted with M10 x 1 threaded fuse wells. The switch is dual function and can operate in a 'Pull' or 'Pressure' mode. The UMNP-1 is a small precision made switch that has been manufactured from a non corrosive metal. This helps to ensure good weather proofing properties. Four green plastic prongs are mounted on the top of the switch, these aid concealment and have a metal ring attachment fitted which enables the use of a tripwire.

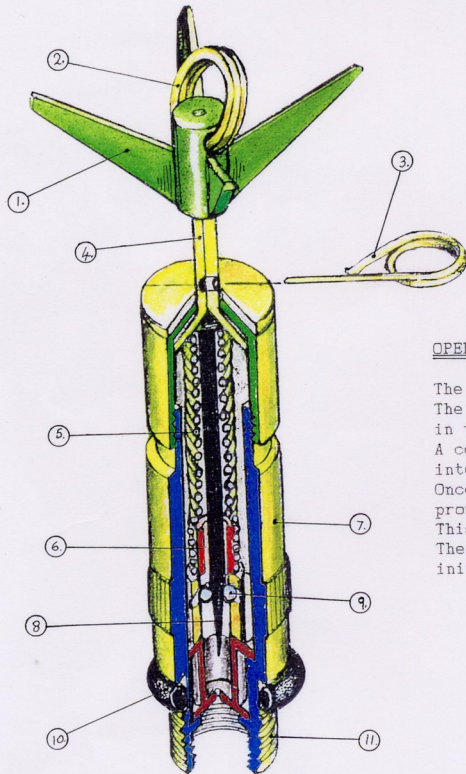

SECTIONED VIEW OF THE SWITCH

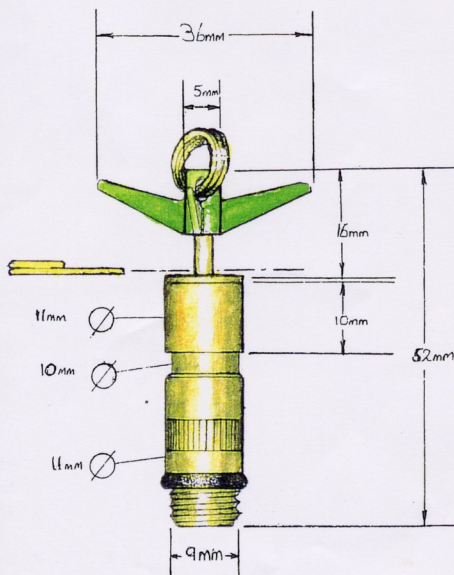

DIMENSIONS OF THE SWITCH

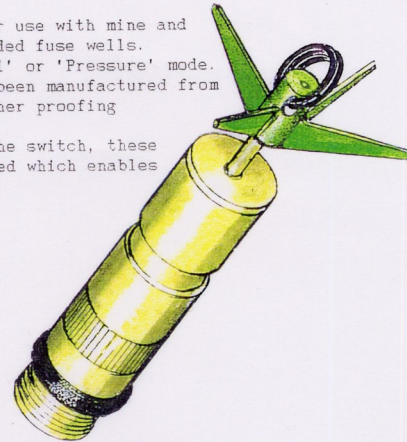

GENERAL VIEW OF THE UMNP-1

OPERATION OF THE SWITCH

The switch operates on a 'spring operated, ball control' method. The 'Cocked/Sprung' striker is retained by ball bearings that are engaged in the inner wall of the fuse body. A central retaining plug prevents the ball bearings from being able to move into their escape holes. Once the safety pin is removed and pressure/tension is applied to the prongs, the spring can bend and move the retaining plug. This allows the ball bearings to escape and release the striker. The striker is propelled into the stab sensitive detonator assembly initiating the explosive train.

COMPONENTS

- 1.- Plastic Prongs.
- 2.- Tripwire Attachment.
- 3.- Safety Pin.
- 4.- Spigot.
- 5.- Striker Spring.
- 6.- Striker.
- 7.- Body.
- 8.- Retaining Plug.
- 9.- Ball Bearings. (2)
- 10.- Rubber Washer.
- 11.- M10 x 1 Thread.



UMNP-1 SWITCH

UMNP-1 FITTED TO

TW100 & TW200

This turns the demolition charges into mines.

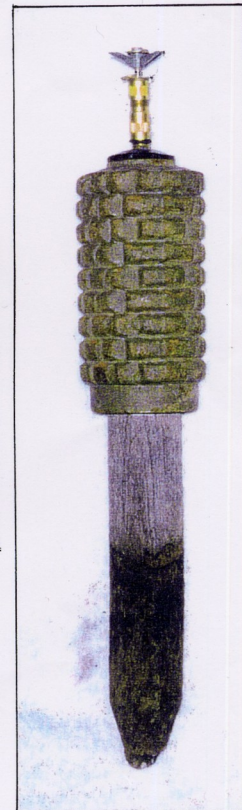

UMNP-1 FITTED TO PMR-2

R & S GRAVETT
21 WATER DICHAMPTON
WILTON SALISBURY
WILTSHIRE
01722-744061

©
1998

UMOP-1

Type – Pressure-Release/Pull
Weight - 0.7 oz. (22 g)
Length – 2.9 in. (76 mm)
Diameter – 0.4 in. (12 mm)

The UMOP-1 is a firing device capable of being initiated by pressure release or pull. It is intended for use as a boobytrap, or an anti-lift device for anti-tank mines fitted with secondary fuze wells. Internally, the device functions in much the same manner as the UMP-1 firing device.

The firing device consists of a cylindrical steel body, containing a cocked-striker assembly, and a disc-shaped pressure plate retained by a radial safety pin secured by a lockwire. The lower end of the device body contains a permanently attached detonator assembly. The spring-loaded striker assembly is retained by three steel balls engaged inside the body. An actuating rod, attached to the pressure plate, runs axially through the center into a hollow striker. The narrow end of the rod holds the retaining balls against the wall of the device body. The striker spring also bears on the base of the pressure plate, so it is under constant pressure. It is retained in position by a safety pin secured by a thin lockwire. The safety pin also holds back a lightly sprung collar, which upon removal covers the safety pin holes thus preventing neutralization.

To use the firing device in the pressure release mode, it is inserted into a mine or explosive charge and a load exceeding 7.7lbs (3.5kg) is placed on top of the pressure plate. The lockwire and safety pin are then removed causing the collar to move up and engage in a recess on the underside of the pressure plate. Alternatively, the firing device can be placed in the bottom of an anti-tank mine (or an explosive charge exceeding 3.5kg) and emplaced. The lockwire is then removed, and the safety pin withdrawn, preferably from a remote location.



*UMOP-1V Practice Firing Device (disassembled)
Photo – Fenix Insight*



UMOP-1 Firing Device

To use the UMOP-1 in the tripwire mode, the device is inserted into an explosive charge or mine. No external load is required. A tripwire is then attached to the safety pin, stretched out, and anchored to a secure object. The lockwire is removed to fully arm the device.

The separate firing pin of the cocked-striker assembly is held in check by three retaining balls. Removing the

weight from the pressure plate, or removing the safety pin, allows the cocked striker assembly to rise within the device body, until the lock balls fall free, releasing the firing pin onto the percussion cap of the detonator assembly.

The body of the firing device is unpainted; however, the designation of the device is stenciled in black on the body. A training version of the firing device, UMOP-1V ("V" is an abbreviation for the term "Vežbovni," which translates as "Exercise," or "Practice"), was also produced and can be identified by a yellow band around the body, as well as the lack of an integral detonator assembly.

UMP-1 (YMII-1)

Type – Pull
Length – 3.0 in. (77 mm)
Diameter – 0.4 in. (11 mm)

The UMP-1 is a tripwire activated pull firing device used in mines and other explosive charges. Internally, the device functions in much the same manner as the UMOP-1 firing device.

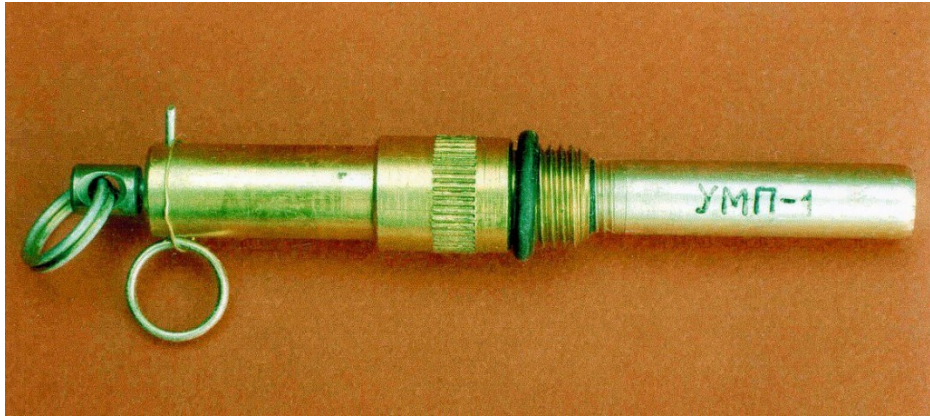

*UMP-1 Firing Device
Photo – Fenix Insight*

The firing device consists of a steel body with an integral detonator assembly. A striker assembly is contained in the upper part of the device with radial safety pin secured by lockwire. The spring-loaded striker is held back by retaining balls engaged inside the tubular fuze body. An actuating rod, fitted with a ring, runs axially through the center of the firing device and into the hollow striker. The grooved end of this rod holds the retaining balls out against the wall of the firing device body. When 3.5 to 5.9lbs (1.6 to 2.7kgs) of tension is applied to the pull ring on the actuating rod, it and the attached striker are pulled back in the body compressing the striker spring. As the actuating rod pulls back the retaining balls roll out of their groove in the rod, and fall into the center of the hollow striker. This releases the firing pin and allows it to fly forward into the percussion cap in the detonator assembly which initiates the attached explosive charge or mine. The lower portion of the body is knurled and contains the detonator assembly. The detonator assembly is bonded onto the end of the fuze body to create a waterproof seal and prevent removal.

To use the firing device, it is screwed into a demolition charge and emplaced with the device horizontal. One end of the tripwire is deployed and anchored in place. The opposite end is attached to the pull ring on the striker. Finally the lockwire and safety pin are removed arming the device.

When used in a mine the firing device functions as an anti-lift device. It is screwed into a secondary fuze well on the bottom of the mine. Both the firing device and mine are emplaced with a short wire attached to the pull ring and anchored in place. The lockwire and safety pin are removed and the mine covered. The device is now ready to function.

The body of the firing device is unpainted, but the attached detonator assembly may have UMP-1

stenciled on it in either Croatian Latin or Serbian Cyrillic. A training version of the firing device, UMP-1V (“V” is the abbreviation for the term “Vežbovni,” which translates as “Exercise,” or “Practice”), was also produced and is identified by a yellow band around the body, as well as the lack of an integral detonator assembly.

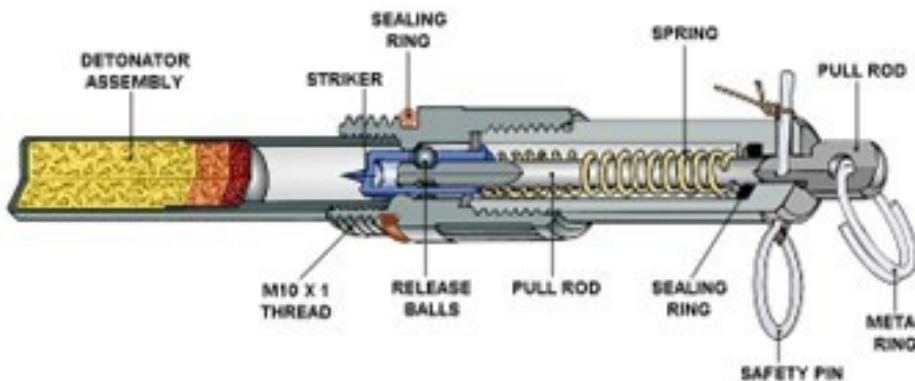

*UMP-1 Firing Device
Image – B.Gravett*

UMP-2

Type – Pull

Weight – 0.2 oz. (6 g)

Length – 2.5 in. (66 mm)

Diameter– 0.4 in. (12 mm)

The UMP-2 is a tripwire activated, radial pull firing device used in both mines and other explosive charges. In operation, the device is similar to the Russian MUV series of firing devices.

The firing device consists of a steel body housing a striker assembly, as well as an integral detonator assembly. The midsection of the device incorporates a knurled plastic collar threaded on one end to allow it to be screwed into a mine or demolition charge. Two pins pass through the striker assembly where it protrudes from the firing device body. The upper one is designed for safety and the other for firing. The top of the firing device is sealed by an O-ring with a metal washer on top. The lower pin bears on the washer to compress the seal. In transit and storage, both pins are secured in place by a lockwire.

To use the firing device, it is screwed into a mine or demolition charge, emplaced and camouflaged. Tripwires (there can be more than one) are attached to the lower radial pin and secured. The firing device body is free to rotate within the plastic collar and will turn to face the direction of pull before the pin is fully withdrawn. The lockwires and the upper safety pin are removed. The lower pin, including a section bent around the neck of the striker to hold it safely in place, is rotated 180° from the locked position to the armed position. The device is now ready to function.



UMP-2V Firing Device



*UMP-2V Practice Firing Device (disassembled)
Image – Fenix Insight*

When any of the deployed tripwires are pulled the fuze body will rotate within the plastic collar in the direction of pull. When the pull exceeds 4-13lbs (2-6kg), the pin is withdrawn allowing the striker to strike the percussion cap in the detonator assembly, initiating the attached mine or demolition charge.

The body of the firing device is unpainted and without markings but the midsection collar assembly is green



plastic. A training version of the firing device, UMP-2V (“V” being an abbreviation for the term “Vežbovni,” which translates as “Exercise,” or “Practice”), was also produced and can be identified by a yellow band around the body, as well as the lack of an integral detonator assembly.

UMP-2 Firing Device with detonator assembly

UPM-1

Type – Pressure/Pull

Weight – 0.9 oz. (26 g)

Length – 3.3 in. (84 mm)

Diameter – 0.5 in. (12.7 mm)

The UPM-1 is a firing device initiated by either radial pressure or pull. It is commonly employed in mines but can also be used for boobytrap purposes. The UPM-1 is an almost exact copy of the Second World War German Z.Z.42 firing device and the Czech RO-1 firing device. The original designation of this firing device was DUM-47.

In operation, the UPM-1 functions in the same manner as the Russian MUV firing device.

The firing device consists of a brown or black Bakelite and brass body, a striker assembly and a combination safety and pull/pressure pin. The safety pin has a slight rise in it to ensure that it stays in the safe position until rotated. Both the striker and pin are made of steel. A plastic shipping and storage cap covers the end of the firing device.



*UPM-1 Firing Device
Photo – G. Zahaczewsky*



*Yugoslav UPM-1 (left) and German Z.Z.42 (right)
Firing Devices
Photo – G. Zahaczewsky*

To use the firing device in the pull mode, remove the shipping cap and attach a detonator. Insert the device into a mine or demolition charge. Deploy a tripwire, one end anchored, and attach the other to the safety pin. Finally the safety pin is rotated 180° to the armed position.

When used in the pressure mode, the UPM-1 is most commonly used with a pressure-activated box-type landmine, such as the Russian PMD-6. When pressure is applied to the safety pin forcing it out of the striker assembly, the striker is released and allowed to hit the percussion cap of the detonator assembly initiating the attached explosive charge or mine.

The body of the firing device is unpainted, and there are no visible markings.

UPM-2

Type - Pull

Weight - 0.6 oz. (18.5 g)

Length - 2.2 in. (57 mm)

Diameter - 0.5 in. (12.7 mm)

The UPM-2 is a simple cocked-striker firing device initiated by radial pull. It is commonly employed in mines but can be inserted into a demolition charge as a boobytrap.

The firing device consists of a black Bakelite body, a striker assembly and a combination safety and pull pin. A plastic shipping and storage cap covers the end of the firing device.



UPM-2 Firing Device

To use the firing device, the shipping cap is removed, and a detonator attached. The device is then inserted into a mine or demolition charge. A tripwire is deployed, one end is anchored, while the other end is attached to the safety pin. The safety pin is then rotated 180° to the armed position. When the safety pin is withdrawn the striker is released and allowed to hit the percussion cap of the detonator assembly initiating the attached explosive charge or mine.

The body of the firing device is unpainted, and there are no visible markings.

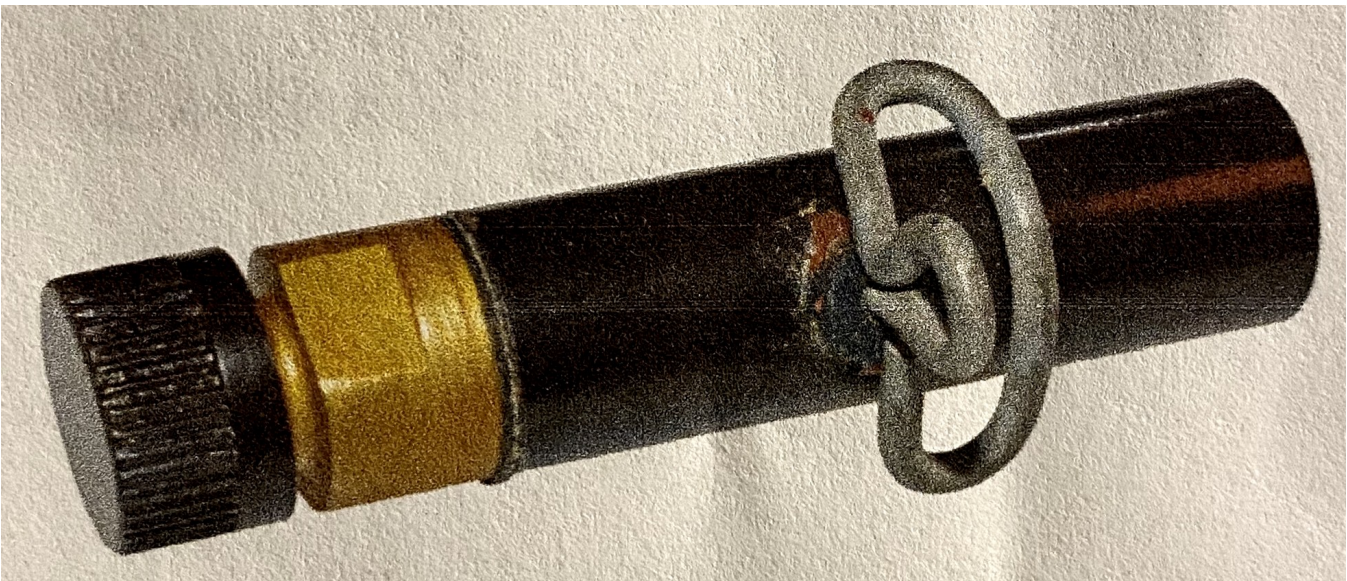

UPM-2 Firing Device

UPMNP-1

Type – Pull

The UPMNP-2 firing device is initiated by either axial or radial pull. It is most commonly employed in PMR-3 antipersonnel mines but can be used with demolition charges or landmines for boobytrap purposes.



UPMNP-1 Firing Device

The firing device consists of a metal body containing a cocked-striker assembly, an axial actuator rod with pull ring, a radial safety collar and an integral detonator assembly.

To employ the firing device, it can be vertically inserted into the PMR-3 or an explosive charge, or can be horizontally inserted into a demolition charge or secondary fuze well of an antitank mine. Anchored tripwires are then attached to the pull ring on the actuator rod, and the safety collar removed. More than one tripwire may be attached to the firing device as it will function on either axial or radial pull. The firing device, with the attached explosive, is then camouflaged.

The body of the firing device is unpainted, and there are no visible markings.

No further technical or operational details are known about this device.

UPP

Type – Pressure-Release
Weight – 3.7 oz. (105 g)
Length – 3.0 in. (76 mm)
Width – 2.1 in. (53.3 mm)
Height - 0.6 in. (15 mm)



UPP Firing Device
Photo - Mr Fuze

The UPP is a cocked-striker firing device initiated by pressure-release. It is employed primarily as a boobytrap. It is possible that initial stocks of the UPP were actually residual British No. 3, Mk I switches provided by the SOE during the Second World War. However, the post war Yugoslav-manufactured UPP firing devices are almost exact copies of the Second World War British No. 3, Mk I switch.

The firing device consists of a two-piece, hinged steel body, which contains a leaf spring with an attached hammer head, as well as a coiled wire spring. There is also a striker spring that incorporates a protruding striker (firing pin). The three springs provide sufficient force to initiate the percussion cap in the fuse adapter that is screwed into the firing device body. The UPP has a five-hinged body, while the British No.3, Mk I may have five or six. The body contains two cutouts, one in the bottom that is bent up to form an anchor point for a safety pin. The other is angle-shaped in the top of the device and functions as part of the release mechanism. The hammer head has a hole drilled through it to correspond to a hole in the side of the body that accepts the safety pin for the device. As mentioned above, there is also a hole in the firing device body for a fuse adapter, which is opposite of the safety pin hole.

To use the firing device, it is cocked by drawing back on the hammer head and attached spring a safety pin can be inserted into the body to retain it in a cocked position. A fuse adapter is then screwed into the fuse body and attached to an explosive charge. An object weighing at least 1.5lbs is then placed on top of the firing device. The applied pressure allows the safety pin to be removed. If there is resistance in removing the pin, there is insufficient on top of the device.

The UPP operates when the weight on it is removed. This allows the cocked hammer head to move forward and impact the striker, which initiates the attached percussion cap, or attached detonator (blasting cap) and explosive charge.

The body of the firing device is olive green, and there are no visible markings.

USA-T (YCA-T)

Type – Acoustic

Weight – 12.3 oz. (350 g) (incl. battery)

Length – 3.7 in. (94 mm)

Width – 2.8 in. (73 mm)

Height – 1.4 in. (38 mm)

The USA-T is one of a series of special electronic firing devices (also referred to as “super quick fuzes”) manufactured since 1974 by the firm Rudi Cajavec Defence Electronics of Banja Luka in the Former Yugoslavia. It is initiated by an increase in sound levels. The sound level ranges are: 90 dB, 100dB, 110dB, and 120dB. The device also incorporates a 270 – 330 second arming delay.

This firing device was produced as a prototype, and never went into full-scale production or deployment. Further technical or operational details of the USA-T are unknown; however, markings on the device are reported to have been in either Croatian Latin or Serbian Cyrillic.

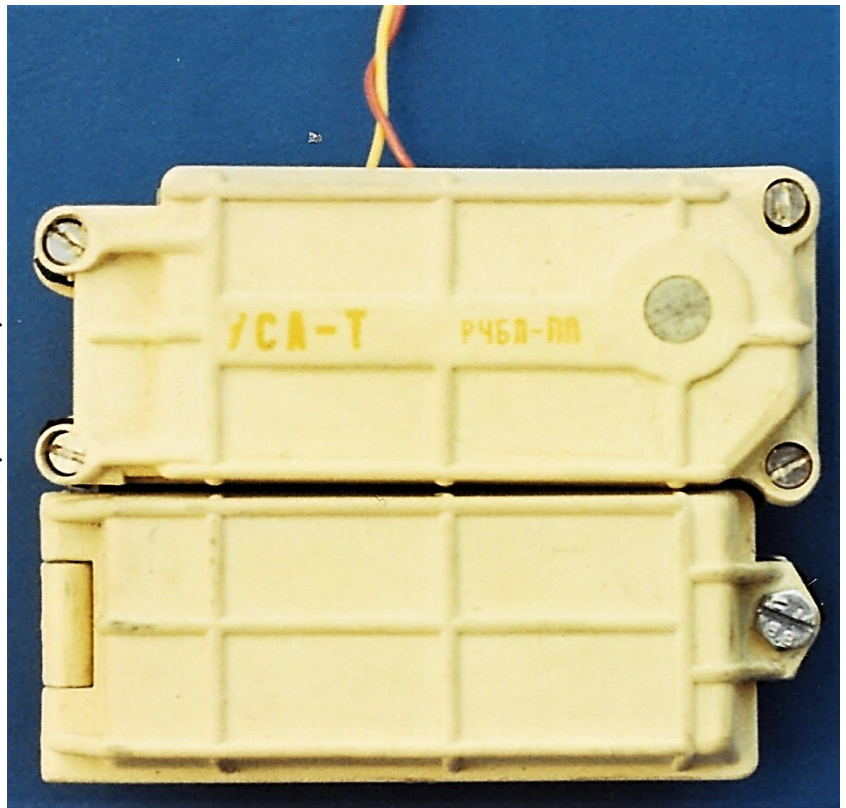

USA-T Special Electronic Firing Device

USD-T (YCD-T)

Type – Inertia/Tilt

Weight – 8.2 oz. (234 g) (incl. battery)

Length – 3.7 in. (94 mm)

Width – 2.8 in. (73 mm)

Height – 1.4 in. (38 mm)

The USD-T is one of a series of special electronic firing devices (referred to as “superquick fuzes”) manufactured since 1974 by the firm Rudi Cajavec Defence Electronics of Banja Luka in the Former Yugoslavia. It is initiated when moved or tilted approximately 30 degrees (+/- 10 degrees).

The firing device consists of a plastic body consisting of two compartments. One section is hinged and contains the battery (a common alkaline or lithium 9V), while the other section is sealed with a tamper indicator compound and contains the potted electronics unit, as well as a movement sensor assembly. The base of the battery compartment contains a plastic shelf that has four circles with numbers 1-12. This has no function in the USD-T. It is commonly found in all versions of the “super quick fuzes” as a battery shelf. The movement sensor assembly consists of two metal wafers separated by an insulation washer. Each wafer is concave so that when the two are assembled, a small chamber is created that allows three metal balls inside to move freely. When the device senses sufficient movement, the balls shift and bridge the two metal wafers completing an electrical circuit. The detonator/firing leads (red and yellow) extend from one side of the case. The safety pin is inserted in one end of the electronics compartment depressing an internal microswitch that disconnects the negative lead from the battery. With a high quality alkaline 9V battery, the firing device has a reputed 2,500-hour life expectancy. A lithium 9V battery could almost double the life expectancy

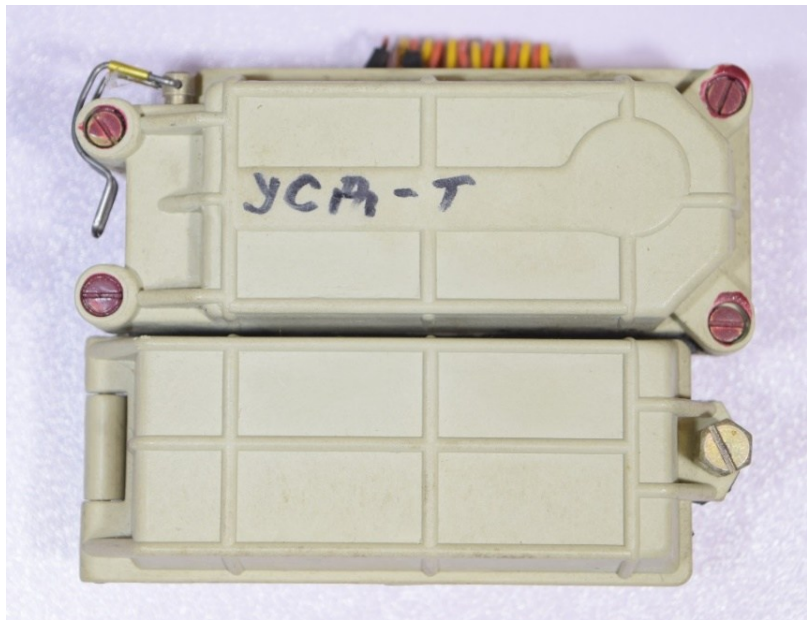

*USD-T Special Electronic Firing Device
Photo – G. Zahaczewsky*



*USD-T battery compartment
Photo- Bob Leiendecker*

To use the firing device, a detonator is connected to the firing leads and inserted into an explosive charge. The firing device and explosive charge are then camouflaged. Placement of the firing device is crucial to its deployment – the firing circuit must be open before the device is armed, otherwise it will detonate upon the expiration of the arming delay. Therefore, the firing device should be placed as level as possible. The final step is to remove the safety pin. This will initiate an approximate five-minute arming delay that, upon expiration, will fully arm the device by charging a firing capacitor in the electronics unit. When the firing device is moved or tilted approximately 30 degrees

it will complete the circuit. The device may be disarmed by reinserting the safety pin depressing the microswitch disconnecting the negative battery lead and discharging the firing capacitor.

The body of the firing device is unpainted, but has its designation stenciled in yellow or black. Markings may be found in either Croatian Latin or Serbian Cyrillic.

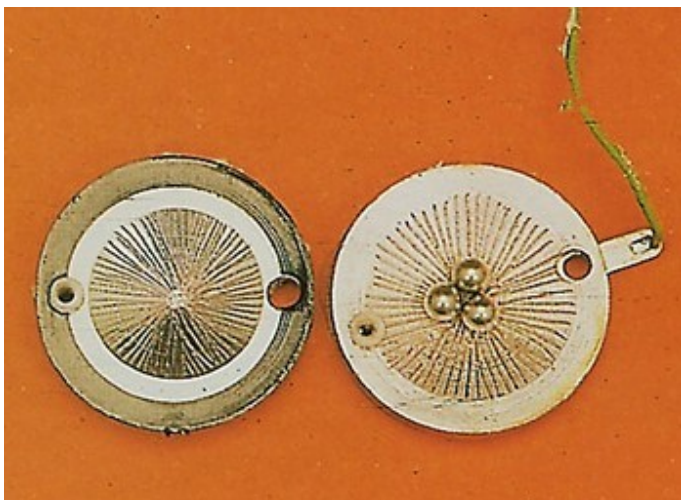

*USD-T movement sensor
Photo – US Department of Defense*



*USD-T with packaging
Photo- Bob Leiendecker*

USD-T (YCD-T)

Type – Multifunction
Weight – 10.5 oz. (300 g)
Length – 3.7 in. (94 mm)
Width – 2.8 in. (73 mm)
Height – 1.4 in. (38 mm)

The multifunction USD-T combines the functions of several special electronic firing devices (also referred to as “superquick fuzes”) manufactured since 1974 by the firm Rudi Cajavec Defence Electronics of Banja Luka in the Former Yugoslavia. It combines the functions of the USD-T (tilt), USS-T (light sensitive), and UEPZh (breakwire) firing devices. It can readily be distinguished from the regular USD-T by the presence of a red indicator light and photoelectric cell on the top surface, as well as two blue breakwires extending from one side.

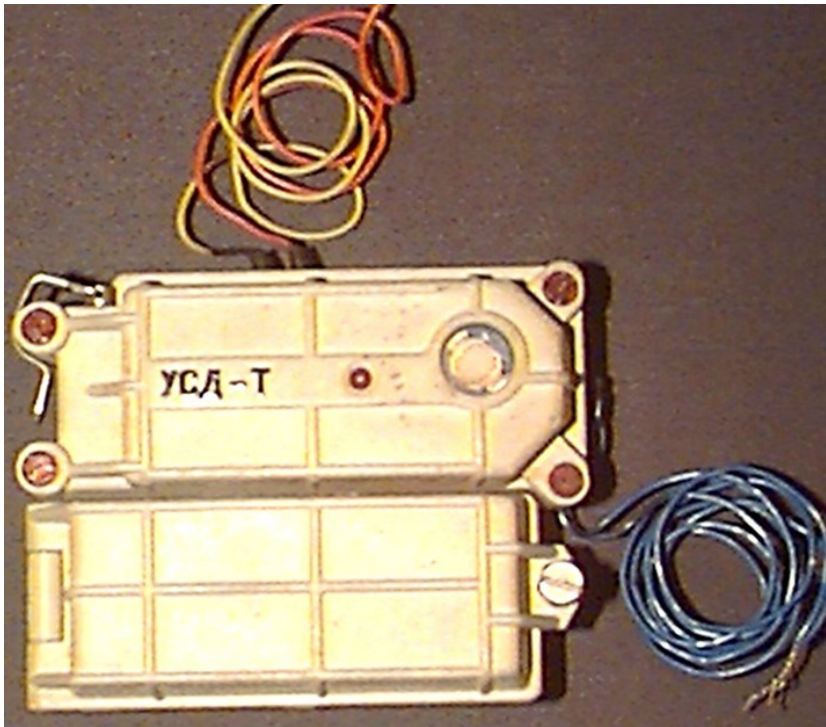

USD-T Special Electronic Firing Device

The firing device consists of a plastic body consisting of two compartments. One section is hinged containing the battery (a common alkaline or lithium 9V), while the other section is sealed with a tamper indicator compound containing the potted electronics unit, as well as a movement sensor assembly. The base of the battery compartment contains a plastic shelf that has four circles with numbers 1-12. This has no function in the regular USD-T; however, set into one of the circles is an adjustable potentiometer for light sensitivity for the Multifunction USD-T. The movement sensor assembly consists of two metal wafers separated by an insulation washer. Each wafer is concave so that when the two are assembled, a slight chamber is created that allows three metal balls inside to move freely. When the device senses sufficient movement, the balls shift and bridge the two metal wafers, thus completing an electrical circuit. Extending from one side of the case are the detonator/firing leads (red and yellow). Also extending from the side of the firing device are two blue-colored breakwire leads. A red LED indicator that verifies the breakwire circuit integrity and a light sensitive photoelectric cell are visible on the top surface of the device. The safety pin is inserted in one end of the electronics compartment and depresses an internal microswitch disconnecting the negative lead from the battery. With a high quality alkaline 9V battery, the firing device has a reputed 2,500-hour life expectancy. A lithium 9V battery could almost double life expectancy.

To use the firing device, the light sensitivity/trigger level is adjusted by turning the potentiometer in the battery compartment. The red LED verifies that the system is working. If the breakwire feature is to be utilized, an appropriate amount of breakwire is deployed to cover the targeted area and connected to the breakwire leads extending from the device. Placement of the firing device is crucial to its deployment – the firing circuit must be open before the device is armed, otherwise it will detonate upon the expiration of the arming delay. The red LED then goes out to indicate that the device is “safely laid” i.e. when the breakwire has a complete circuit, the photoelectric cell is covered from light and the device is set level. If the LED is illuminated there is a fault and the lay of the device must be checked. Once the LED is out a detonator can be connected to the firing leads and inserted into an explosive charge. The firing device and explosive charge are then camouflaged.

. The final step is to remove the safety pin. This will initiate an approximate five-minute arming delay that, upon expiration, will fully arm the device by charging a firing capacitor in the electronics unit. The firing device will function if one of the following actions occurs: (1) it is moved or tilted

approximately 30 degrees (+/- 10 degrees); (2) the device's light sensor is illuminated; (3) the breakwire is severed by a 6.6lb (3kg) pull. The device may be disarmed by reinserting the safety pin, depressing the microswitch which disconnects the negative battery lead as well as discharging the firing capacitor.

The body of the firing device is unpainted, but has its designation stenciled in yellow or black. Markings may be found in either Croatian Latin or Serbian Cyrillic.

USE-T (YCE-T)

Type – Delay
Weight – 7.7 oz. (221 g)
(incl. battery)
Length – 3.7 in. (94 mm)
Width – 2.8 in. (73 mm)
Height – 1.4 in. (38 mm)

The USE-T is one of a series of special electronic firing devices (referred to as “super quick fuzes”) manufactured since 1974 by the firm Rudi Cajavec Defence Electronics of Banja Luka in the Former Yugoslavia. It has an arming delay of 300 seconds and is initiated after a maximum time delay of 9,999 minutes.



*USE-T Special Electronic Firing Device
Photo – G. Zahaczewsky*

The firing device consists of a plastic body consisting of two compartments. One section is hinged and contains the battery (a common alkaline or lithium 9V), while the other section is sealed with a tamper indicator compound and contains the potted electronics unit, as well as a quartz crystal-controlled time base for the main delay. The base of the battery compartment contains a plastic shelf that has four circles, labeled x1000, x100, x10, and x1. The plastic shelf is commonly used in all versions of the “super quick fuzes” as a battery support. In the USE-T, rotary switches accessed through each circular hole in the plastic shelf are used to set the desired time delay. The detonator/firing leads (red and yellow) extend from one side of the casing. The safety pin is inserted in one end of the electronics compartment depressing an internal microswitch that disconnects the negative lead from the battery. With a high quality alkaline 9V battery, the firing device has a reputed 2,500-hour life expectancy. A lithium 9V battery could almost double the life expectancy

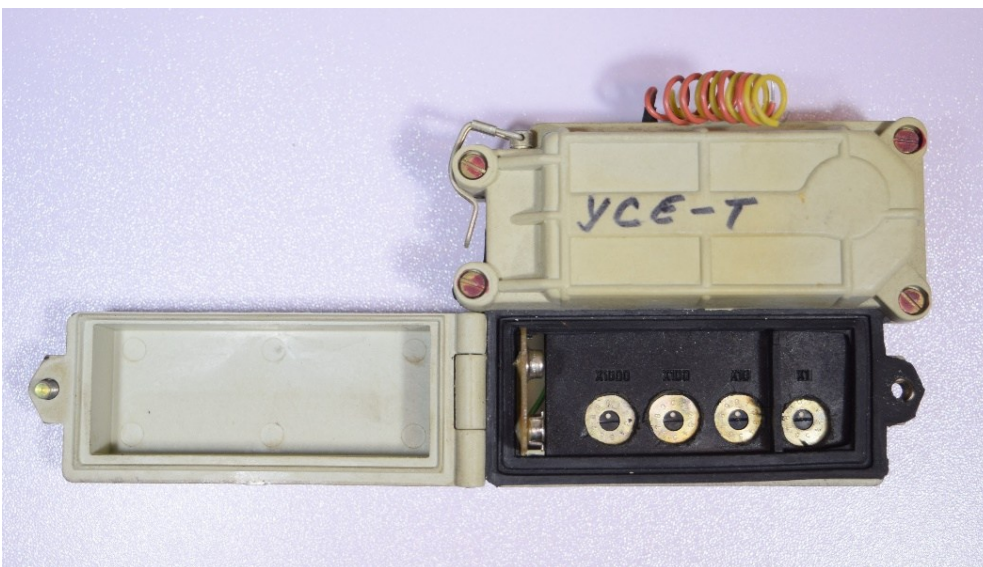

*USE-T battery compartment
Photo – G. Zahaczewsky*

To use the firing device, the individual timing dials are set, and a detonator connected to the firing leads and inserted into an explosive charge. The next step is to camouflage the device and explosive charge. The final step is to remove the safety pin, initiating an approximate five-minute arming delay that, upon expiration, will fully arm the firing device by charging a firing capacitor in the electronics unit. When the preset delay runs down the charge will explode. The device may



be disarmed by reinserting the safety pin, depressing the microswitch which disconnects the negative battery lead as well as discharging the firing capacitor.

The body of the firing device is unpainted, but has its designation stenciled in yellow or black. Markings may be found in either Croatian Latin or Serbian Cyrillic.

*USE-T time setting dials
Photo – G. Zahaczewsky*

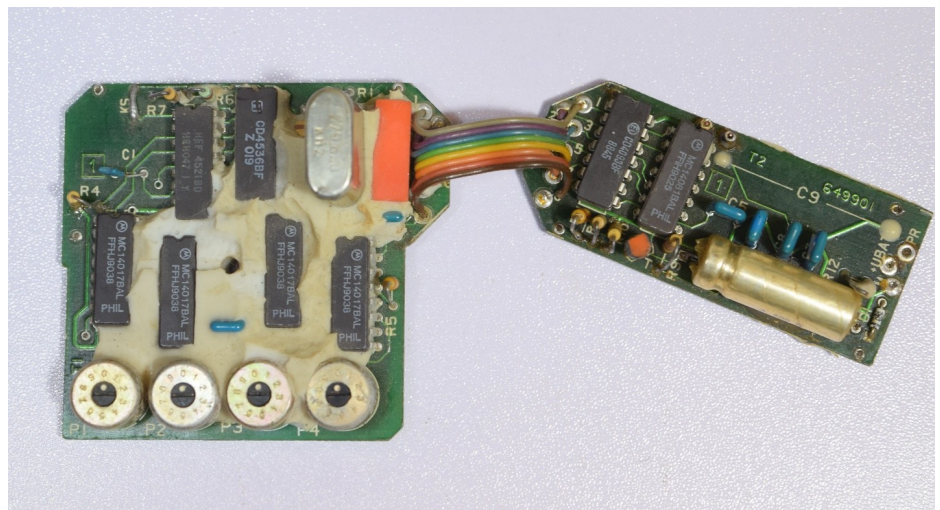

*USE-T potted electronic circuitry (NOTE Motorola semiconductors)
Photo – G. Zahaczewsky*



*USE-T with packaging
Photo- Bob Leiendecker*

USHNP-1

Type – Pressure-Release/Pull

Weight – 2.8 oz. (80 g)

Length – 3.7 in. (94 mm)

Diameter – 0.5 in. (12.7 mm)

The USHNP-1 is a pressure release or pull firing device intended for boobytrap or sabotage operations. These firing devices may have been produced in limited quantities, as there are no credible reports of their actual use.



The firing device is constructed of plastic and aluminum. The plastic body includes an aluminum pressure rod, as well as a radial safety pin. The device is shipped complete with a percussion detonator assembly installed and protected by a plastic sleeve.

USHNP-1 Firing Device
Photo – US Department of Defense

To use the USHNP-1, the protective sleeve, as well as the cork safety between the striker and blasting cap, must be removed. In the pressure mode, the firing device must be attached to a stable surface. A small < 2.2lb (< 1kg) board should then be placed on top of the rod. When 2.2 – 22lb (1 - 10kg) of force is applied to the rod, the pre-weakened end of the striker assembly is sheared allowing the rest of the spring-loaded firing pin to impact the detonator initiating the charge. In the pull mode, a weight exceeding 2.2lb (1kg) is placed on top of the pressure rod. A tripwire is then attached to the safety pin. When the safety pin is pulled out the weight causes the device to function. No further information is currently available.

USHP-1

Type – Pull

Weight – 0.3 oz. (10 g)

Length – 1.7 in. (45 mm)

Width – 0.4 in. (10 mm)

The USHP-1 is a pull-activated friction firing device intended for boobytrap operations. These firing devices were probably produced in limited numbers, as there are no credible reports of their actual use.



*USHP-1 Firing Device
Photo – US Department of Defense*

The firing device consists of what appears to be an aluminum or plastic body, with a radial safety pin. A string is attached to a pull friction assembly in the top of the device.

To use the firing device, a flash sensitive detonator assembly is attached to the end of the device. The USHP-1 is then inserted into an explosive charge. The firing device is activated when a 2.25 to 25.5lbs (1 to 11.5kg) axial pull is exerted on the initiation assembly after the safety pin has been removed. This action pulls a spiral wire through a friction sensitive ignition compound, which initiates the flash detonator. The EHU-5 (5 second) and EHU-10 (10 second) delays may be used with this firing device to provide a delayed detonation.



EHU-5/EHU-10 Delay

USHT

Type – Pull

Weight – 0.3 oz. (10 g)

Length – 1.5 in. (40 mm)

Diameter – 0.2 in. (6 mm)

The USHT is a pull activated firing device intended for boobytrap operations.

The firing device consists of a fuze body and an attached removable detonator assembly.

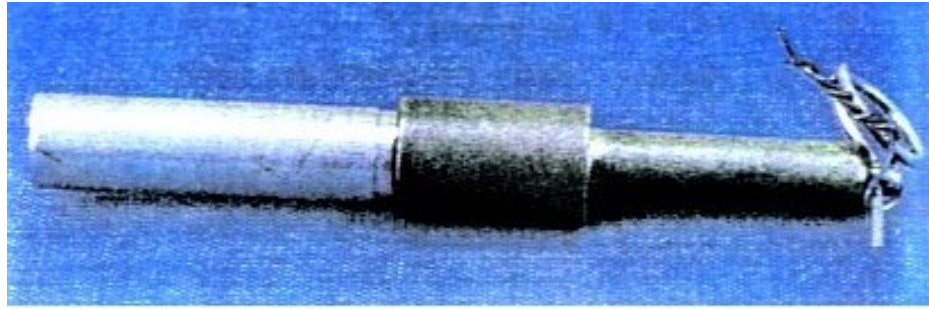

USHT Firing Device
Photo – US Department of Defense

A force of 0.4 – 4.4 pounds (0.2 – 2 kg) is required to initiate the device.

No further technical or operational details are known about this device.

USHT-1

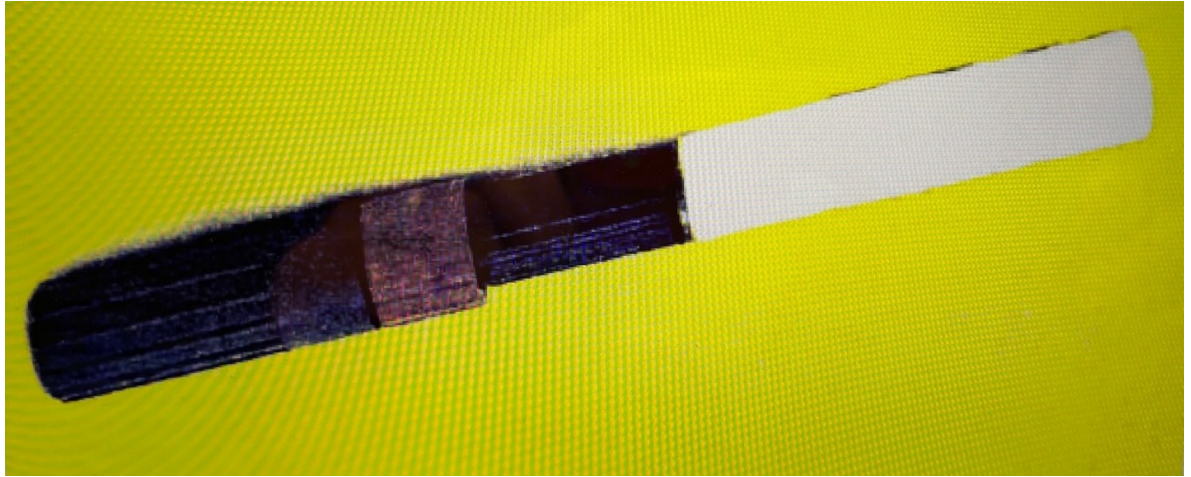

USHT-1 Firing Device
Photo – US Department of Defense

Type – Delay

The USHT-1 is a chemical delay firing device intended for sabotage operations. These firing devices are intended to initiate a variety of explosive charges. They were probably produced in limited numbers, and there are no credible reports of their actual use.

The firing device consists of a fuze body, with a removable detonator assembly. The device is activated when a glass ampoule in the fuze body is crushed. This releases a corrosive liquid that will initiate the detonator after a selectable 0.5, 3, or 6-hour delay.

No further technical or operational details are known about this device.

USHTZ-1



USHTZ-1 Firing Device
Photo – US Department of Defense

Type – Delay

The USHTZ-1 is a chemical delay firing device intended to initiate incendiary charges in boobytrap or sabotage operations. As there are no credible reports of their actual use they were likely produced in limited numbers.

The device consists of a fuze body, with a removable igniter cartridge. The device is activated when a glass ampoule in the fuze body is crushed releasing a corrosive liquid that will initiate the igniter cartridge after a selectable 0.5, 3, or 6-hour delay.

No further technical or operational details are known about this device.

USI-T (YCH-T)

Type – Inertia/Tilt
Weight – 7.7 oz. (221 g)
(incl. battery)
Length – 3.7 in. (94 mm)
Width – 2.8 in. (73 mm)
Height – 1.4 in. (38 mm)

The USI-T is one of a series of special electronic firing devices (referred to as “super quick fuzes”) manufactured since 1974 by the firm Rudi Cajavec Defence Electronics of Banja Luka in the Former Yugoslavia. It is initiated when it is moved or tilted. The device incorporates a 270 – 330 second delay.

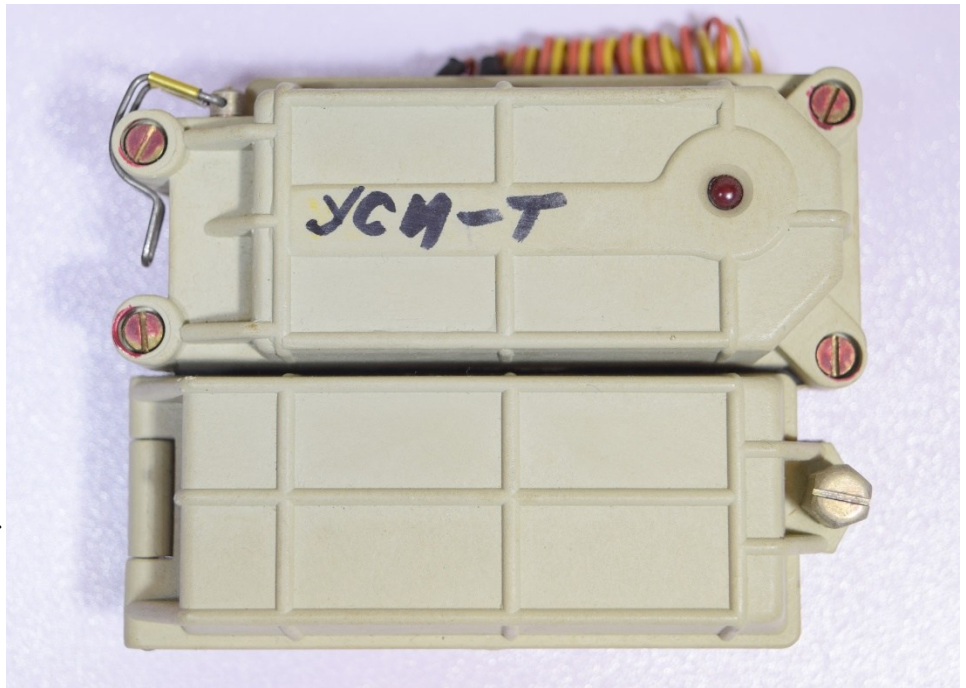

*USI-T Special Electronic Firing Device
Photo – G. Zahaczewsky*

The firing device consists of a plastic body of two compartments. One section is hinged and contains the battery (a common alkaline or lithium 9V), while the other section is sealed with a tamper indicator compound and contains the potted electronics unit with an exposed red LED, as well as an embedded mercury switch. The base of the battery compartment contains a plastic shelf that has four circles with numbers 1-12. This has no function in the USI-T but is commonly found in all versions of the “super quick fuzes.” The detonator/firing leads (red and yellow) extend from one side of the case. The safety pin is inserted in one end of the electronics compartment. The safety pin depresses an internal microswitch that disconnects the negative lead from the battery. With a high quality alkaline 9V battery, the firing device has a reputed 2,500-hour life expectancy. A lithium 9V battery could almost double the life expectancy.

To use the firing device, a detonator is connected to the firing leads and inserted into an explosive charge. The firing device and explosive charge are then camouflaged. Placement of the firing device is crucial to its deployment – the firing circuit must be open before the device is armed, otherwise it will detonate upon the expiration of the arming delay. The red LED is an emplacement aid that will glow when the circuit is closed. The firing device should be repositioned until the LED goes out indicating that the firing circuit is open. The final step is to remove the safety pin. This initiates an approximate five-minute arming delay that, upon expiration, will fully arm the firing device by charging a firing capacitor in the electronics unit. All that remains is for the firing device to be moved or tilted approximately 30 degrees. The device may be disarmed by reinserting the safety pin, depressing the microswitch which disconnects the negative battery lead as well as discharging the firing capacitor.

Overall, the USI-T is a lower-quality production model of the USD-T tilt special electronic firing device. Component bending, soldering, use of inferior wires, less potting, and general assembly are not up to previous standards on the special electronic fuzes. The device also shares components with several other “super quick fuzes.” The body of the USI-T device is used for the UEPZh, the printed circuit board is similar to those used in the USS-T photoelectric and the UST-T thermal sensitive firing devices. The body of the firing device is unpainted, but has its designation stenciled in yellow or black. Markings may be found in either Croatian Latin or Serbian Cyrillic.

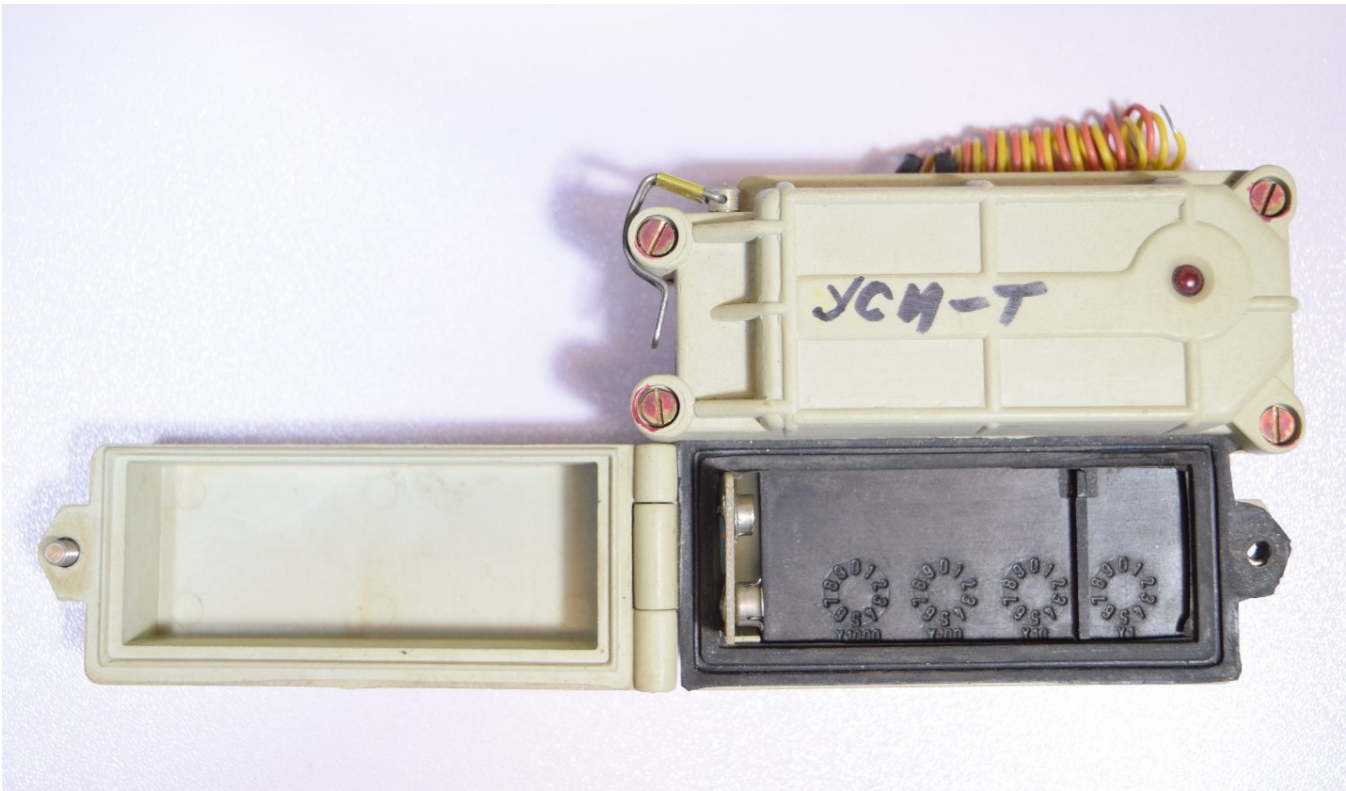

*USI-T battery compartment
Photo – G. Zahaczewsky*



*USI-T with packaging
Photo- Bob Leiendecker*

USKhT-1 (YCЖT-1)

Type – Delay

Length – 3.5 in. (90 mm)

Diameter – 0.4 in. (10 mm)

The USKhT-1 is a chemical delay firing device intended for boobytrap or sabotage operations.

The firing device consists of an aluminum, color-coded cartridge assembly containing a glass ampoule filled with corrosive liquid, and an attached plastic firing device body containing a cocked striker and striker spring. The striker is restrained by a copper wire susceptible to erosion by the corrosive liquid in the cartridge assembly. Felt washers separate the two assemblies.

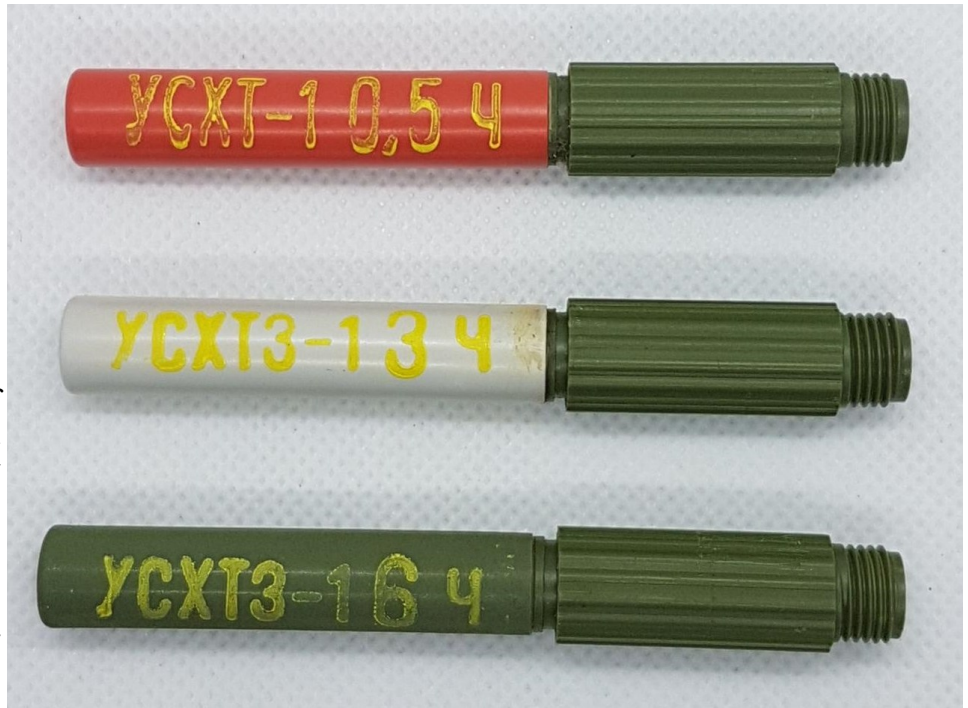

USKhT-1 Firing Device

To use the firing device, a percussion activated detonator assembly is screwed onto the end of the device. The firing device is then inserted into an explosive charge, and both concealed. The firing device is activated when the glass ampoule in the aluminum cartridge assembly is crushed. This releases the corrosive liquid which soaks the felt washers and erodes the copper retaining wire in the body. This action releases the striker onto the percussion cap in the detonator assembly, which initiates the attached explosive charge.

The cartridge portion of the firing device body is color-coded red (0.5 hrs.), white (3 hrs.), or olive drab (6 hrs.) to indicate the delay time of the device. Yellow markings in Serbian Cyrillic on the cartridge assembly indicate the designation and delay time. The plastic body is olive green in color.

USS-T (YCC-T)

Type – Photoelectric
Weight – 8.8 oz. (250 g)
(incl. battery)
Length – 3.7 in. (94 mm)
Width – 2.8 in. (73 mm)
Height – 1.4 in. (38 mm)

The USS-T is one of a series of special electronic firing devices (also referred to as “super quick fuzes”) manufactured since 1974 by the firm Rudi Cajavec Defence Electronics of Banja Luka in the Former Yugoslavia. It has an arming delay of 270 – 330 seconds, and is initiated when exposed to a light source ranging from 2 to 7 Lux.

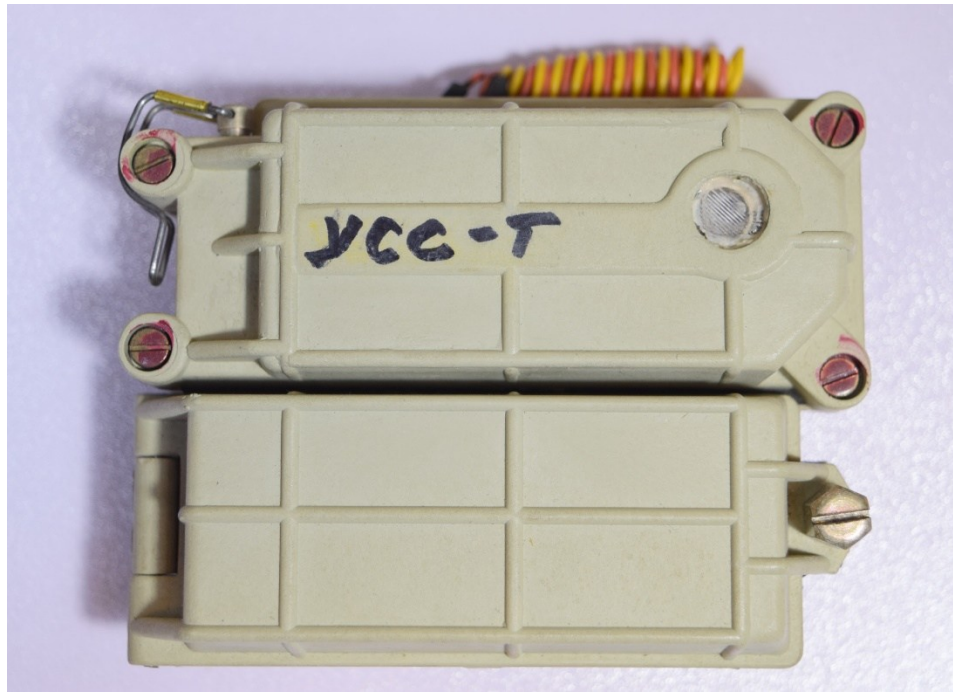

*USS-T Special Electronic Firing Device
Photo – G. Zahaczewsky*

The firing device consists of a plastic body consisting of two compartments. One section is hinged and contains the battery (a common alkaline or lithium 9V), while the other section is sealed with a tamper indicator compound and contains the potted electronics unit with an exposed photoelectric cell. The base of the battery compartment contains a plastic shelf that has four circles with numbers 1-12. The circles have no function in the USS-T; however, set into one of the circles is an adjustable potentiometer for light sensitivity. The plate is commonly found in all versions of the “super quick fuzes.” Extending from one side of the case are the detonator/firing leads (red and yellow). The safety pin is inserted in one end of the electronics compartment depressing an internal microswitch that disconnects the negative lead from the battery. With a high quality alkaline 9V battery, the firing device has a reputed 2,500-hour life expectancy. A lithium 9V battery could almost double the life expectancy.

To use the firing device, the light sensitivity/trigger level is adjusted by turning the potentiometer in the battery compartment. A detonator is then connected to the firing leads and inserted into an explosive charge. The firing device and explosive charge are then camouflaged. The final step is to remove the safety pin, initiating an approximate five-minute arming delay that, upon expiration, will fully arm the firing device by charging a firing capacitor in the electronics unit. The device will detonate the charge when the light sensor is illuminated. The device may be disarmed by reinserting the safety pin, depressing the microswitch which disconnects the negative battery lead and discharging the firing capacitor.

The body of the firing device is unpainted, but has its designation stenciled in yellow or black. Markings may be found in either Croatian Latin or Serbian Cyrillic.

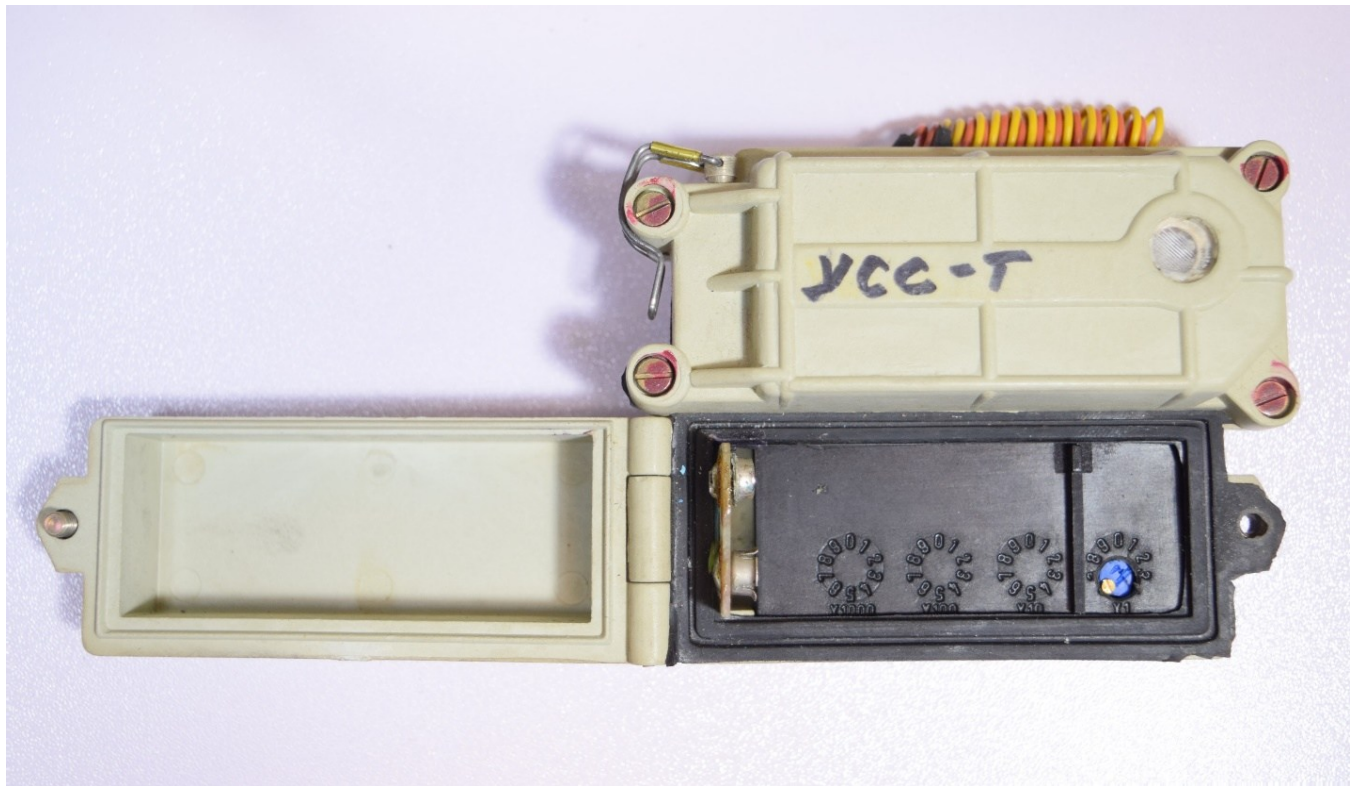

*USS-T battery compartment showing the adjustable potentiometer on the right
Photo – G. Zahaczewsky*



*USS-T with packaging
Photo- Bob Leiendecker*

UST-T (YCT-T)

Type – Thermal

Weight – 12.3 oz. (350g) (incl. battery)

Length – 3.7 in. (94 mm)

Width – 2.8 in. (73 mm)

Height – 1.4 in. (38 mm)

The UST-T is one of a series of special electronic firing devices (also referred to as “super quick fuzes”) manufactured since 1974 by the firm Rudi Cajavec Defence Electronics of Banja Luka in the Former Yugoslavia. The firing device has a 220 – 330 second arming delay. It is initiated when exposed to an increase in temperature. The temperature range is ambient to approximately 100 C.

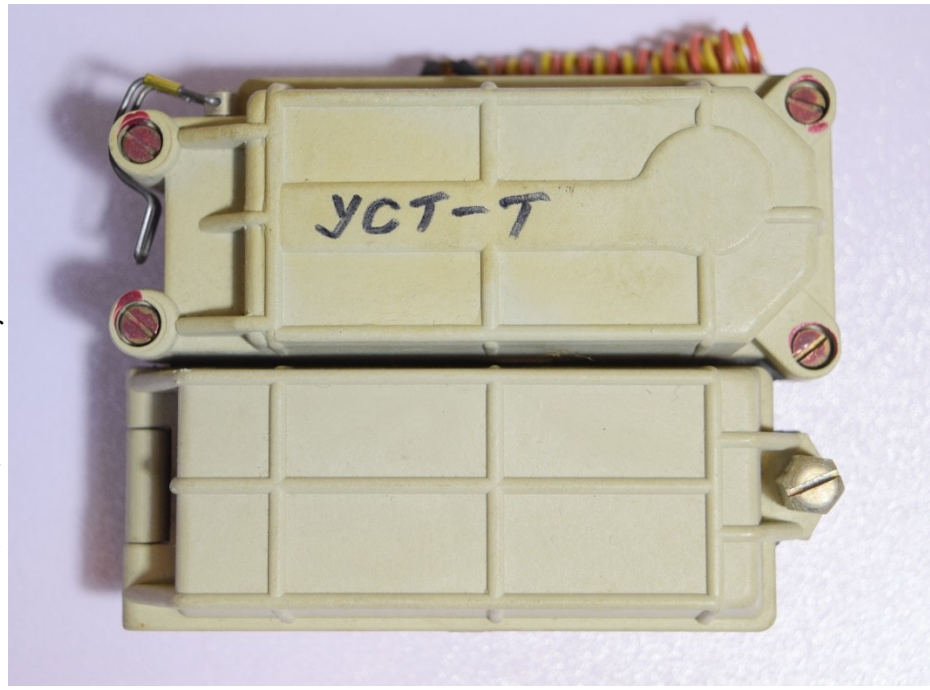

*UST-T Special Electronic Firing Device
Photo – G. Zahaczewsky*

The firing device consists of a plastic body consisting of two compartments. One section is hinged and contains the battery (a common alkaline or lithium 9V). With a high quality alkaline 9V battery, the firing device has a reputed 2,500-hour life expectancy. A lithium 9V battery could almost double life expectancy. The other section is sealed with a tamper indicator compound and contains the potted electronics unit with a flush-mounted 5mm stud on the backside connected to a temperature sensor in the electronics unit. The base of the battery compartment contains a plastic shelf that has four circles numbered 1-12. The circles have no function in the UST-T; however, set into one of the circles is a potentiometer controlling the temperature trip point. The plate is commonly found in all versions of the “super quick fuzes.” Extending from one side of the case are the detonator/firing leads (red and yellow). The safety pin is inserted in one end of the electronics compartment, The safety pin depresses an internal microswitch disconnecting the negative lead from the battery.

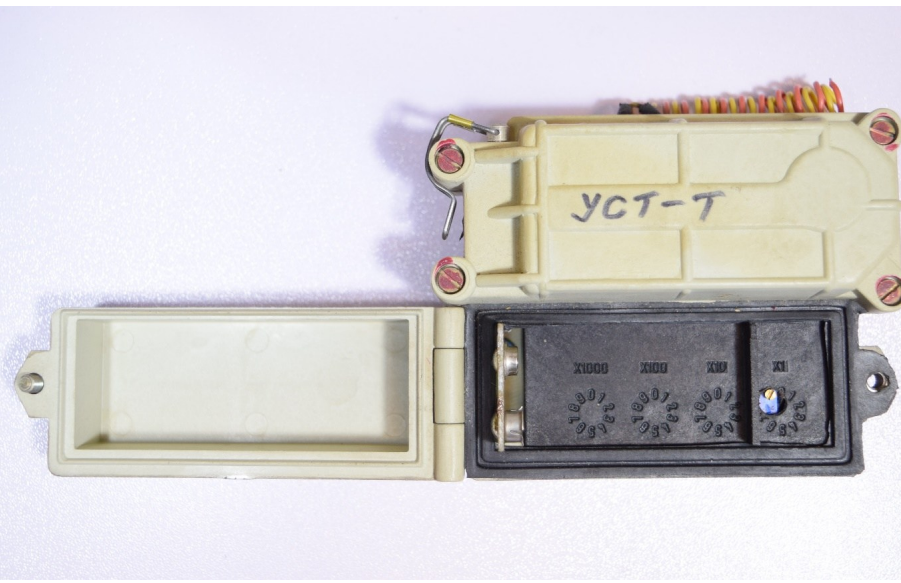

*UST-T battery compartment showing the adjustable potentiometer on the right
Photo – G. Zahaczewsky*

To use the firing device, the thermal sensitivity/trigger level is adjusted by turning the potentiometer in the battery compartment. A detonator is connected to the firing leads and inserted into an explosive charge. The firing device and explosive charge are then camouflaged. The final step is to remove the safety pin, initiating an approximate five-minute arming delay that, upon expiration, will fully arm the firing device by charging a capacitor in the electronics unit. All that remains is for the firing device’s thermal sensor to

detect a change in temperature. The device may be disarmed by reinserting the safety pin, depressing the microswitch that disconnects the negative battery lead and discharges the firing capacitor.

The body of the firing device is unpainted, but has its designation stenciled in yellow or black. Markings may be found in either Croatian Latin or Serbian Cyrillic.

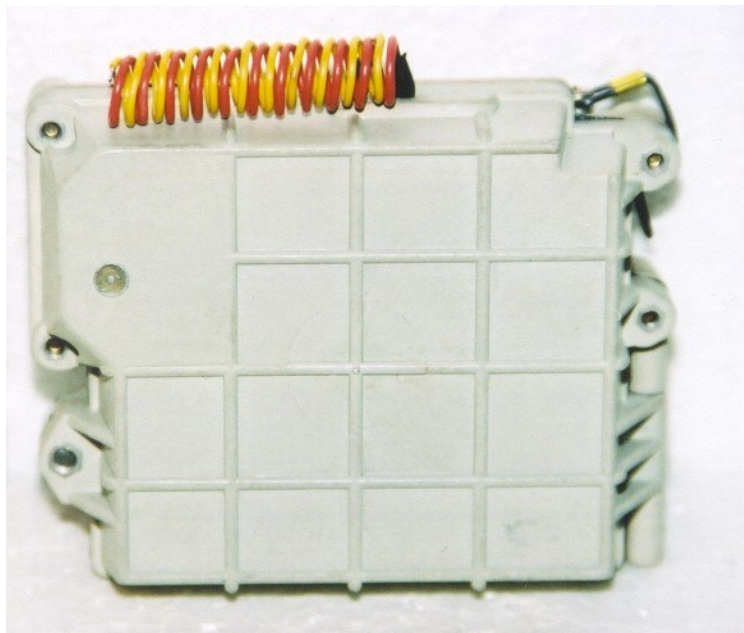

*UST-T reverse showing the thermal sensor on the left
Photo – G. Zahaczewsky*

*UST-T thermal sensor
Photo – G. Zahaczewsky*

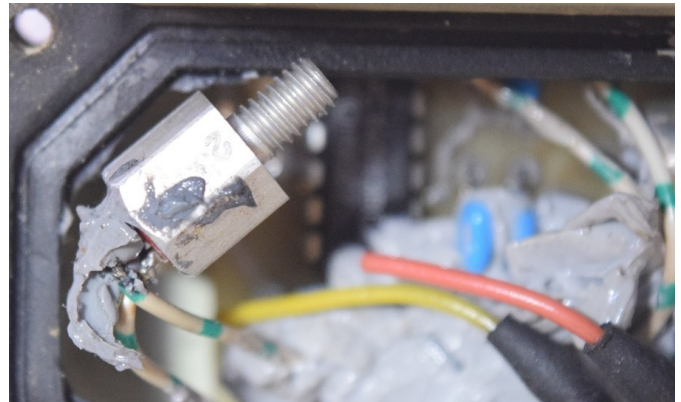

*UST-T with packaging
Photo- Bob Leindecker*

USV-T (YCB-T)

Type – Vibration

Weight – 12.3 oz. (350 g) (incl. battery)

Length – 3.7 in. (94 mm)

Width – 2.8 in. (73 mm)

Height – 1.4 in. (38 mm)

The USV-T is one of a series of special electronic firing devices (also referred to as “super quick fuzes”) manufactured from 1974 by the firm Rudi Cajavec Defence Electronics of Banja Luka in the Former Yugoslavia. It is initiated when it experiences changes in vibrations. The vibration levels are: 0.001 m/s², 0.01 m/s², 0.1 m/s², and 1 m/s².

This firing device was produced as a prototype, and never went into full-scale production or deployment. Images of the firing device have not been found, and further technical or operational details of the USV-T are unknown; however, markings on the device are reported to have been in either Croatian Latin or Serbian Cyrillic.

U-TE

Type – Delay

Weight – 2.9 oz. (84 g) (w/o battery)

Length – 2.5 in. (65 mm)

Width – 1.4 in. (37 mm)

Height – 0.9 in. (23 mm)

The U-TE is a clockwork delay firing device designed for demolition and sabotage operations. The time delay ranges from one to 12 hours.

For use, set the desired delay time, insert a 1.5V battery in the bottom of the firing device, then attach an electric detonator. Insert the detonator into an explosive charge. The final step is to initiate the time delay and camouflage the charge.

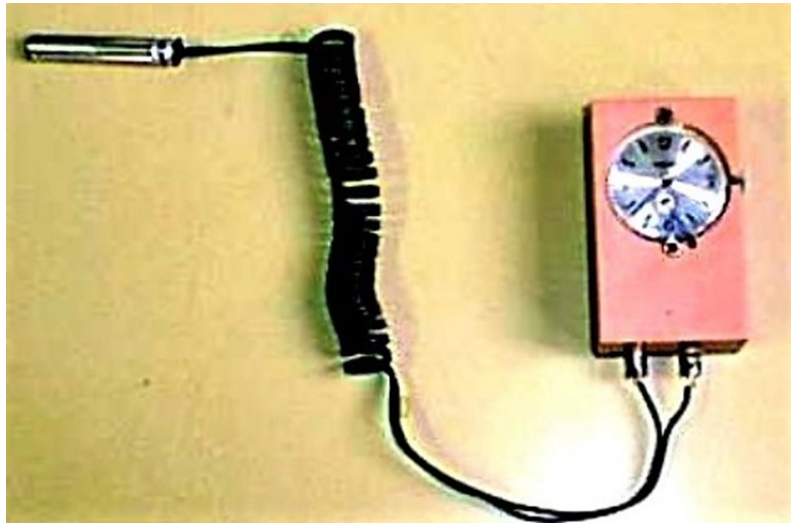

*U-TE Firing Device
Photo – US Department of Defense*

Upon expiration of the time delay, the clock hand will touch a contact post to close an electric circuit and initiate the detonator and explosive charge.



*U-TE Firing Device (bottom view showing battery
compartment)
Photo – Bob Leindecker*

UV-24 (YB-24)

Type – Training

Weight – 12.3 oz. (350 g) (incl. battery)

Length – 3.7 in. (94 mm)

Width – 2.8 in. (73 mm)

Height – 1.4 in. (38 mm)

The UV-24 is the training version of a series of special electronic firing devices (also referred to as “super quick fuzes”) manufactured since 1974 by the firm Rudi Cajavec Defence Electronics of Banja Luka in the Former Yugoslavia. Initiation possibilities include time delay, tilt, or breakwire.

It is uncertain if this firing device achieved full-scale production as only a few samples have been reported. Further technical or operational details of the UV-24 are unknown. Markings on the device are reportedly in either Croatian Latin or Serbian Cyrillic.



*UV-24 Special Electronic Firing Devices
Photos - Erhard Koch*



YUGOSLAVIA-ELECTRONIC DEVICES

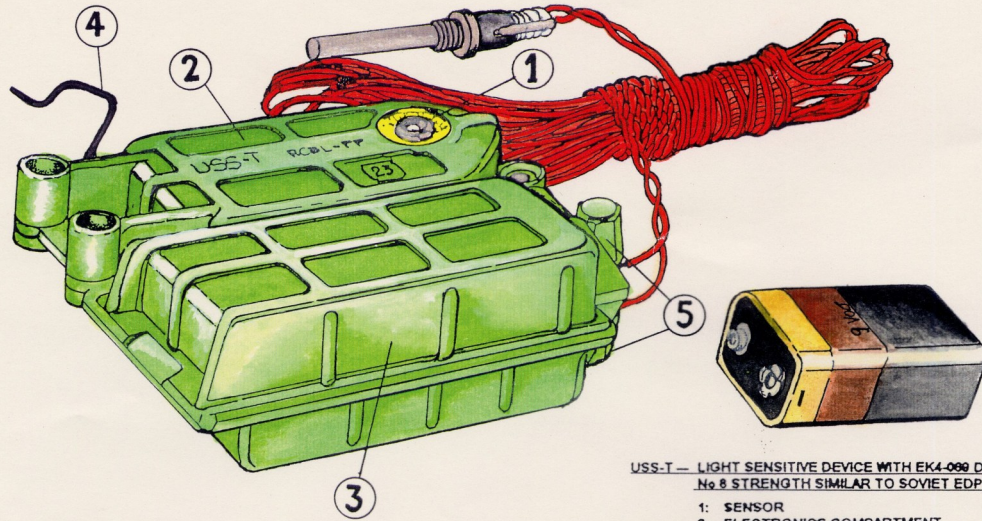

USS-T— LIGHT SENSITIVE DEVICE WITH EK4-099 DETONATOR
No 8 STRENGTH SIMILAR TO SOVIET EDP-r

- 1: SENSOR
- 2: ELECTRONICS COMPARTMENT
- 3: BATTERY COMPARTMENT
- 4: ARMING KEY
- 5: TERMINALS

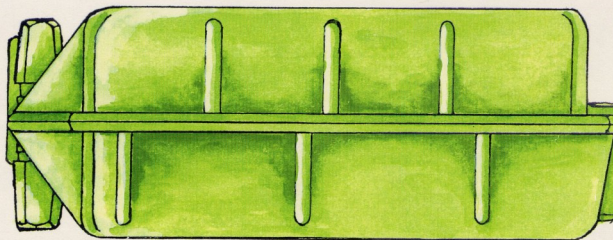
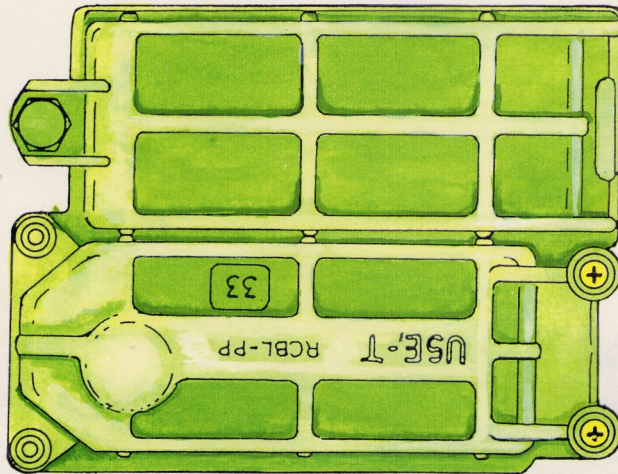

Common Technical Data

Dimensions:	90 x 70 x 35 mm
Weight:	250 gms
Time to Arming:	270 - 330 secs
Temperature Operating Range:	-30 ^o C to +60 ^o C
Battery supplied:	Type 6F 22.9 volts
Detonator supplied:	Type EK 4069
Resistance:	1.4 - 1.8 Ohms
Safe Current:	0.28 Amps
Firing Circuit:	0.8 Amps
Delay to Firing:	4 - 12 Msec
Leading Wires:	350 mm

USI-T	Inertia sensitive	(US \bar{I} - Inertia)
UST-T	Thermal Type	(US \bar{T} - Thermal)
USS-T	Light Sensitive	(US \bar{S} - Solenoid)
USE-T	Electronic timer	(US \bar{E} - Electronic timer)

R & S GRAVETT
STABLES FLAT
WILTON HOUSE
WILTON, SALISBURY
* SP2 0BJ
TEL: 0722 744061

R & S GRAVETT
STABLES FLAT
WILTON HOUSE
WILTON, SALISBURY
* SP2 0BJ
TEL: 0722 744061

Manufacturers in this volume

Rudi Cajavec Defence Electronics, Banja Luka, Former Yugoslavia

Credits for all books in TBRM series

This is by no means a complete list of credits or references. Many other people and institutions have helped in the production of these publications.

Australian War Memorial
Bomb Techs Without Borders
Norman Bonney
Bernt Bosman
Darrol Vincent Bowlzer
Francis Caley
Mike Eldredge
Jim Geibel
Timothy Holland
Fenix Insight
Terry Keller
Colin King
Kyle Kochan
Jouko Kuisma
Rick Larson
Bob Leiendecker
Scott Lynch
Oleksandr Mariash
Leo Monkivitch
Jeff Osborne
Drew Prater
Dave Sampson
A. Skrobot
T. Mathew Smith
Colin MacGregor Stevens

T. Mathew Smith
Colin MacGregor Stevens
CAT-UXO

References

Many Official Documents, Military Manuals, Training Circulars, notes and reports.

Commercial books.

Tombe Du Ciel
SOE Equipment Air dropped in Europe
Malice Aforethought
The British Spy Manual
Winston Churchills Toyshop
Station 12, SOE's Secret Centre
Secret Agents Handbook of Special Devices
The Plumber's Kitchen
OSS Weapons II, Second Edition
SOE, The Scientific Secrets

Eric Pierret
Anders Thygesen & Michael Sode
Ian Jones MBE
IWM
Stuart Macrae
Des Turner
Mark Seaman
Donald B. McLean
Dr. John W. Brunner, Ph.D.
Frederick Boyce and Douglas Everett

Websites

<http://tgrm.foxed.ca/>

<http://visualcollector.com/VisualCollectorLinks/Traps.htm>

<http://www.bocn.co.uk/vbforum/>

<http://www.millsgrenades.co.uk/>

<http://www.lexpev.nl/>

<https://www.wk2ammo.com/forum.php?s=2acb9706ceecdd4ff1a5074bde7eae88>

<http://archives.library.wcsu.edu/findingaids/gilbert.xml>