

The Boobytrap Recognition Manual

Vol. 2
American



D.W. Lynn
2019, updated 2026

Copyright © Darryl W. Lynn
2019

This is a free publication, not to be sold.

This volume is dedicated to:

Jim Geibel

1948-2019

A consummate professional who contributed greatly to this publication.

Introduction

This publication is a result of my frustration trying to find those little tidbits of information that are spread throughout many books manuals and papers. It is my attempt at putting it all in one place making it easier to find. I hope you will also find it useful.

This publication will only detail officially manufactured mechanisms, I will not attempt to describe any improvised devices or methods.

It should be noted that the photos are certainly not all mine, I have been collecting photos from other collectors, museums and off the net for years and as a result of poor record keeping in many cases have no idea where I found them. If you find one of your photos in here and your name is not in the credits, please accept my apologies for using it without permission.

This book is not simply my effort, many people have contributed to its completion, have read it over, offered corrections and pointed out blatant errors. You know who you are and my thanks for your help. If you happen to find one of those errors, please let me know so I can correct it.

Enough said, on to the interesting bits.....

Index

Content	Page
Firing Device, Pull, M1 (old style).....	1
Modified British Pull Switch.....	2
Firing Device, Pull, M1 (new style).....	3
Firing Device, Pull, M2.....	5
Firing Device, Pull/Release, M3.....	7
Firing Device, Pull A2 (OSS).....	9
Firing Device, Pressure, M1 (old style).....	10
Firing Device, Pressure, M1 (new style).....	11
Firing Device, Pressure, M1A1.....	13
Firing Device, Pressure, A1 (OSS).....	15
Firing Device, Pressure, A2 (OSS).....	15
Firing Device, Pressure, A3 (OSS).....	15
Firing Device, Release, M1.....	17
Firing Device, Release, M5.....	19
Firing Device, Release, A1 (OSS).....	21
Firing Device, Release, A2 (OSS).....	21
Firing Device, Combination, M1.....	22
Fuze, Mine, Anti-Personnel, M2/M2A1.....	23
Fuze, Mine, Anti-Personnel, M3/M3A1.....	23
Combination Firing Device, Mk. 1 Mod. 0.....	24
Demolition Firing Device, Mk. 1 Mod. 1.....	25
Firing Device, Demolition, Multi-Purpose, M142.....	27
Detonator Kit, Concussion, M1.....	31
Demolition Firing Device, Mk. 6 Mod. 0.....	32
Firing Device, Delay, M1.....	33
Signal Relay Incendiary.....	36
Destructor (Demolition) Mk. 1 Mod. 0 and Mk. 1 Mod. 1.....	35
Firing Device, Clockwork, Mk. 3.....	37
Firing Device, Clockwork, 24 Hr.	38
Firing Device, Clockwork, 24 Hr. (CIA).....	39
Firing Device, Demolition, Mk12 Mod. 0/Mk. 13 Mod. 0/Mk. 15 Mod. 0.....	40
Firing Device, Demolition, Mk12 Mod. 1/Mk. 13 Mod. 1/Mk. 15 Mod. 1.....	42
Firing Device, Demolition, Delay Type, Electronic, M147.....	46
Timer, Interval, Training Kit, M45.....	47
Firing Device, AC Delay, Mk. 1.....	43
Igniter, Fuse, Fog Signal.....	49
Fuse Lighter, M1.....	55
Lighter, Fuse, Weatherproof, M2.....	56
Lighter, Fuse, Weatherproof, M2, Inert.....	56
Igniter, Time Blasting Fuse, Weatherproof, M60.....	57
Igniter, Time Blasting Fuse, M81, w/Shock Tube Capability.....	59
Detonator, Friction, 15 Second Delay, M1/M1A1.....	50
Detonator, Percussion, 15 Second Delay, M1A2.....	51
Detonator, Friction, 8 Second Delay, M2.....	53
Detonator, Friction, 8 Second Delay, M2, Inert.....	53
Detonator, Percussion, 8 Second Delay, M2A1.....	54
Simulator, Boobytrap, Flash, M117.....	61
Simulator, Boobytrap, Illumination, M118.....	62
Simulator, Boobytrap, Whistling, M119.....	63
Coupling, Base, Firing Device, M1.....	64

Index

Content	Page
Coupling, Base, Firing Device, Non-Metallic, M2.....	65
Coupling Body,	65

The A.C. Gilbert Co.

Prior to the Second World War, the A. C. Gilbert Co. produced toys, magic sets, chemistry sets and toy trains. During WW II they became the primary developer and manufacturer of firing devices for the US. What follows is a history of those developments that was written by the company in 1945. It makes for an interesting read.

A SHORT HISTORY OF FIRING DEVICES

Developed and Produced by The A. C. Gilbert Co.

Many of the items mentioned here are of a confidential nature and precautions should be taken that this report is not available for general distribution.

In February 1942, Major W. L. Erhardt (then 1st Lieutenant) of The Engineer Board, Fort Belvoir, Va. gave us the task of producing two types of Firing Devices, the M1 Pull type Firing Device and the M1 Pressure type Firing Device. Both were copies of devices used by the British with the exception of an American style base for attaching a blasting cap.

With only the Engineer Board drawings and no model, we made hand-made samples and immediately saw means by which they could be improved. On the Pull type we suggested wider slots in the firing pin to give more positive action and to simplify production, also vent slots in the head of the firing pin to prevent piston action which caused misfires, especially with water in the barrel.

On the Pressure type, whose firing pin was a hardened shear pin, we fore-saw premature firing due to the effect of temperature changes or shock to this pin. Also it was impossible for reuse, a desirable feature for training. We, therefore, proposed the keyhole type trigger now in use.

Later we devised an adaptor which would function the device in a vertical position, a screw jack extension for use under higher objects and a three pronged extension, suggested by one used on a German fuze, for better camouflaging. The two latter were made standard equipment.

In March 1942, under Major Erhardt's supervision, we produced a sample of a toggle or tilt type of Pull Device which was studied by The Engineer Board but to our knowledge never adapted.

In April 1942, Major Erhardt brought us a model of a Pull device with a swivel head. The action of this device was such that it jammed fifty percent of the time causing misfires and our suggestions for improving it were requested. We submitted a model with a different action which functioned every time but required more than the desired pull to fire it. Upon further development to correct this fault, we discovered that with a simple alteration the device would function by pressure as well as pull. This was adopted and became known as the M1 Combination Firing Device which was for use by the Ordnance Dept. and called by them the Fuze for Anti-Personnel Mine M2 and M3. At the request of Capt. Marshall of Technical Division of Ordnance, a special base was designed for use with the A.P. Mine M2.

In April 1942, Mr. S. T. Franks from the Office of Coordinator of Information, later known as the Office of Strategic Services, brought us models, drawings, specifications and an order to produce Signal Relays. This was a duplicate of the British Delay Pencil. Only slight changes in this item were suggested which affected a considerable saving by reducing the cost of production. We take pride in our successful manufacture of this Device because of the laboratory accuracy which must be maintained in producing them for the various time delays required.

All these items were using great quantities of brass at a time when brass was at a premium so in August 1942 we submitted models of the M1 Pull, M1 Pressure and M1 Combination to The Engineer Board made of die cast zinc. Not only did these use a less strategic material but with some ingenuity in re-designing we were able to cut the cost of the devices in half without impairing, in any way, the efficiency of the item. Upon acceptance we changed over as quickly as dies could be made.

In August 1942 we experimented with an "L" Delay Device for The Engineer Board. This was a copy of a similar British device. It worked on the tensile strength of various diameters of a notched lead pellet, but was too inconsistent and never adopted.

In September 1942 Major Erhardt, not acquainted with the fact that we were producing Signal Relays, brought us one and asked if we could produce it with an American type base instead of a spring snout. He was pleasantly surprised with the early production date we could give him on these M1 Chemical Delay Firing Devices since it was only necessary to design and tool up for the new base and adapt it to the current production of Signal Relays.

Also in September 1942, Mr. J. P. Roysdon, Mechanical Engineer at The Engineer Board accompanied Major Erhardt and presented us with the problem of designing a friction type igniter, similar to a German device, but to be made of plastics. This little device, M2 Pull, had to be small, waterproof and as non-metallic as possible for booby trapping land mines. Many lots of this device, each lot slightly revised, were produced before the item finally satisfied all the requirements. A quantity was later purchased by the Navy Department for use with an underwater mine.

In November 1942, the Engineer Board submitted samples of the British Anti-Personnel Switch, commonly known as a Foot-shooter, for improvement. The British type were subject to premature firing. We devised an entirely different firing mechanism, which was approved, and produced a quantity for training.

In December 1942, we were asked to design a two (2) minute fuze, a waterproof device to cause a delay of two minutes between the firing of the device and the detonating of the charge. We succeeded in this assignment and submitted models to The Engineer Board but never produced any in quantities.

Also in December we developed a T3 Release type Firing Device similar to the British Release Switch and produced a quantity for training.

At the same time, December 1942, we started some development work for O.S.S. on a Pocket Relay. This was a Signal Relay with a special firing pin which struck a match and ignited a cylinder of thermite. With the assistance of a local fireworks manufacturer, we produced a number of models of this device.

In February 1943, we were called to the Pentagon Building to see Lieut. Col. P. O. Christensen (then Captain) of the Ordnance Department, Technical Division who went over an assembly drawing with us of an idea for an Impulse Delay Pressure type Firing Device, later called Impulse Actuated Firing Device, and asked us to design and build a model of a device which could be set to fire at any one of from one to thirty impulses or pressures applied to the device. A working model and drawings were delivered to him within a month. Several months later twelve more, slightly heavier models were requisitioned and built for the Ordnance Department.

In February 1943 Mr. Roysdon asked us to design a pull device which would also fire upon the release of or cutting the trip wire. The result was the T-3 Pull-Release Firing Device later designated M-3. Originating the mechanism for this device and making it a safe one to handle required considerable ingenuity. The device even has a built-in ratchet in order to obtain the proper tension on the trip wire.

In the same month we started making a Signal Relay Igniter for the Chemical Warfare Department, later for O.S.S. This was a time delay igniter for a pocket incendiary, an improved model of the Pocket Relay described above. We produced the Igniter only.

Shortly afterwards we produced a Special Time Delay unit for Harvard Chemical Laboratory. This functioned in a similar manner to the Pocket Incendiary mentioned above but was a much smaller and lighter unit which was to be dropped in large quantities from a plane and start innumerable fires.

In March 1943 we developed and produced a working model of a Mechanical Time Delay Firing Device which included a clockwork timer that could be set to fire at a predetermined time.

In the same month we started making A2 Type 6 Release Mechanisms and A2 Type 6 Pressure Mechanisms for O.S.S. These were copies of the similar British devices. We encountered considerable difficulty with the latter since the devices for British use and those for American use had to meet different requirements which were not discovered until after production had started and the devices tried in the field. To meet the need of either one was easy, but to combine both in the same device was an almost insurmountable task which was finally accomplished after much experimenting. We also made working models of an automatic extension for this device.

The O.S.S. adopted the American style Pull Type Firing Device instead of a British type since we could very readily convert part of our die capacity to accommodate the changes they required.

In April 1943 Captain Fritsche of the Engineer Board described to us an idea for a firing Device which would be activated by a concussion transmitted under water. The mechanism depended upon a thin glass wafer breaking, allowing the release pin to become free. A model was made and the glass couldn't be depended on to hold the release so it was restrained by a soluble pellet. Considerable research was required on this item both in determining the proper thickness of glass to react to a given concussion and also the best soluble material for the pellet. Since we didn't have the facilities for this sort of work, the development was turned over to Holmes Electric Protective Co. in New York, with us as consultants on the mechanical and production problems and we to produce samples. A satisfactory device was finally produced in quantities. In the meantime, Holmes Electric developed the same device working on a different principal which was a great improvement. At a joint meeting in November 1943 of representatives of N.D.R.C. for whom Holmes electric worked, The Engineer Board, the Navy, Spencer Thermostat Co. and The A. C. Gilbert Co. the new model, operated by a snap diaphragm was disclosed and adopted. We immediately started production on the M1 Concussion Detonator for the Army and the Demolition Firing Device Mark 6 for the Navy, with Capt. Estabrooks of The Engineer Board as the Integrating Officer.

In June 1943, Captain Torbert of The Engineer Board brought us a model of a release Device and asked us to make several samples incorporating some changes from this model. After the samples were approved we produced a quantity for training. In training it was found that further improvements were necessary. Several sets of revised models were made until finally one was produced which satisfied all requirements. This was known as M5 Pressure-Release type Firing Device.

In July 1943, Mr. Roysdon told us the Ordnance Department had requested an improved model fuze for the M2 A.P. Mine, with a safer action and with prongs as on the German fuze for that type of mine. Working with him we developed four different types of device, one of which was chosen to be produced. Samples were submitted to The Engineer Board, to Picatinny Arsenal and to Aberdeen Proving Grounds. This became the T12 and T13, later M6A1 and M7A1 for the Ordnance Department. While producing these we received an emergency call in January 1944 from Lt. Col. Christensen asking if we could produce a special base in a hurry for the T14 Fuze (the same fuze as above with a practice base for training.) To make a base to their blueprint, which was delivered by messenger that night, would require two months of tool work by their contracted facility, but by altering an old M2 base die we could produce a similar base in a much shorter time. The second day after the call we were in Washington with a drawing of the proposed alternate base. It was approved and in less than two weeks from the date of the call we were shipping T14 Bases.

In September 1943, Mr. Roysdon presented a request for a weatherproof fuse lighter which would be absolutely waterproof and show no visible flash. He brought with him a special, quiet, slow-burning primer and a spring snout. By using parts of another device and making a new firing pin and base, we produced for him an acceptable design and he returned to Fort Belvoir with a model the same night. After starting production on this item, we encountered trouble due to variations in this special primer. Availing ourselves of the Winchester Repeating Arm Co.'s proximity and good nature, we tested some of these primers in their laboratory. While there we discovered that its characteristics were in every respect the same as those of the Mark V Hand Grenade Primer which Winchester produces, but that the latter had less variations. We obtained a quantity, assembled them in M2 Fuze Lighters, sent them to The Engineer Board for test, received approval and have been using Mark V Primers ever since with more satisfactory results and a more dependable source of supply.

In October 1943 we submitted to The Engineer Board a working model of a "4 way" device; Pull, Pressure, Release or Pull-Release. A few months later we made accepted improvements on a Navy designed "4 way" Device. Neither device was produced in quantities as the man in the field was too apt to become confused and pull the wrong safety pin.

In January 1944, a representative from N.D.R.C. asked us to submit a design for a "Bushmaster" - a type of decoy weapon. A design was worked up and drawing submitted but we did no further work on it.

In May 1944 we were asked to duplicate, as near as possible, the German "Schu-Mine" for determining methods of mine field clearing. By using an M-2 Fuze Lighter body and firing pin, the base from an M-1 Pull device and a special release pin in a box, to the same dimensions as the German sample, we produced the "Simulated Foreign Demolition Container with Modified Fuse Lighter".

In October 1944, Capt. Hall of the R.D.A., Special Projects Branch of the Ordnance Department asked us to develop an Arming Delay, for a special bomb, similar to a sample he had which was used on another type bomb. We submitted two different models, the second one was accepted and we built a dozen samples for test. The A. C. Gilbert Company design was to be incorporated in the bomb fuze by the producer of the fuze. It was known as the T-3 Arming Delay and cover.

In February 1945, Captain McCord came from Fort Belvoir with a drawing of a special pull firing device to be used in mine field clearing. After certain revisions, to make the device practical from the production standpoint, a working model was made. After it was approved we produced a quantity for test purposes.

222

Also in February 1945 Mr. Roysdon brought up an assortment of Japanese mines and grenades. We are reproducing these in appearance and in certain functioning parts so that the soldier may be trained in detecting and disarming them. These are made up in kits called "Mine Training Aid Set No. 2, Japanese".

Some of these parts are also being produced with other details duplicated so that they may be used as indicators for testing mine clearing methods other than by personnel.

In May 1945 Lt. Col. McIntyre of O.S.S. sent us drawings to produce a "Foot Shooter, Anti-Personnel" which is the same as the one we designed for the Engineer Board with the addition of a short barrel into which the cartridge is placed to make it more effective.

At the same time work was started on a light weight Rocket Launcher mounted on a folding tripod for O.S.S.

In June 1945 Lieut. Pritchard of the Navy visited us for suggestions on waterproofing a delay device to be used under water. A week later Lieut. (j.g.) W. H. Taylor brought in drawings of the device and asked for our opinion of it. After several changes were proposed and made, samples were produced for test purposes.

In practically all cases we made the preliminary detail drawings for The Engineer Board and Ordnance Department and assisted with writing the specifications of the various devices. We also designed the packing for the devices. Many times during the course of production of these items, means were found to improve their functioning, decrease their cost or expedite their production and this information has been passed on to the contracting office.

The men of The A. C. Gilbert Company chiefly responsible for the design and development work on these devices are: Guy Schumacher, Works Manager; V.E. Dowman, Master Mechanic; W. J. Ziebell, Tool and Model Maker and J. E. McLoughlin, Design Engineer.

It is hoped that the various branches of the service will continue with research and development on this type of materiel after the war so that it will not be necessary to depend on our Allies or Enemies for ideas nor on hastily concocted devices for which there is no time for adequate testing or proper training.

Firing Device, Pull, M1 (Old style)

Type- Pull
 Introduced 1942
 Length- 4.75 in.
 Diameter- 5/8 in.
 Body material- Brass

In February 1942 1st Lt. W. L. Erhardt of the Engineer Board, Fort Belvoir, VA gave the task of producing the pull switch to the A. C. Gilbert Co. The firing device was a copy of the British Pull switch (No. 1 Pull, Mk. I) with the exception of using an

American style base coupler. The British switch had been introduced in 1939 and was well proven. Several improvements were suggested by the company including wider slots in the striker and vent slots in the striker head to prevent a piston action which could cause misfires. Both suggestions were accepted. The company produced some 670,000 of this model.



*Firing Device, Pull, M1 (Old style)
 note the anchor wire soldered below the head*

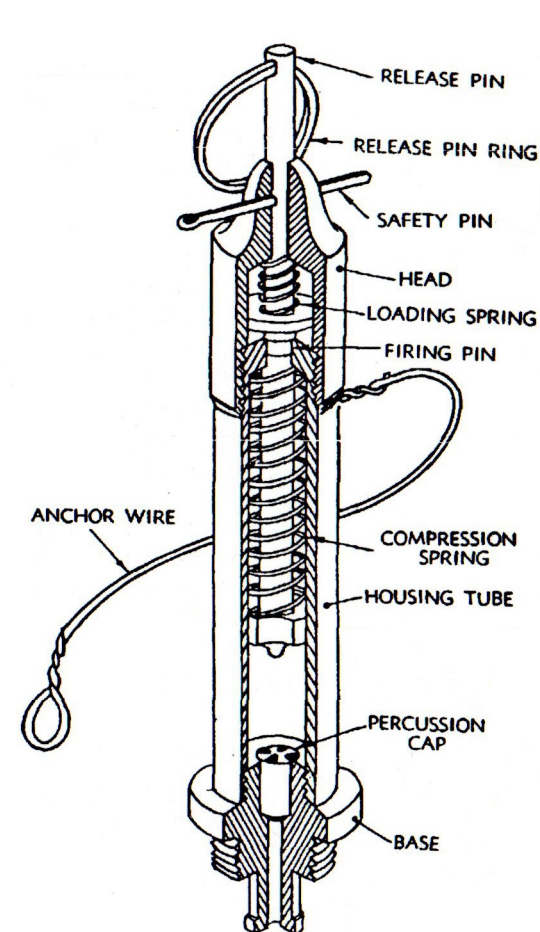

The firing device consists of three main parts, the head, body tube and base coupler. The head and body tube are made of brass. The head is made up of the housing, release pin, loading spring, safety pin and constricting well. The housing is internally threaded to screw onto the body tube. The release pin fits through the bottom up through the top of the housing. The loading spring fits over the release pin and is retained by a washer fixed near the bottom. Once the pin is pushed up the safety pin fits through holes in the housing and release pin to hold it in place. The constricting well screws up into the housing to hold it all together. A split ring is attached to the end of the release pin to allow a wire to be attached.

The body tube is threaded internally at the bottom and externally at the top. It contains the firing pin and firing pin spring. The head screws onto the top of the body tube and is soldered in place. The firing pin is a single piece turned down to form a striker head and shaft with a ridge on the top end. The top end is split to accept the release pin. The striker and spring are pushed up with the split end pushing up through the constricting well in the head to engage the release pin. The release pin pushes the striker end apart so that it cannot pass through the constricting well.

An anchor wire (braided wire) is twisted and soldered onto the firing device just below the head and ends in a loop. The wire is meant to anchor the device in place.

*Firing Device, Pull, M1 (Old style)
 Internal diagram*

The base coupler contains the primer and screws into the bottom of the body tube.

When the device is set, a pull of 3-5 pounds on the wire will pull the release pin up against the pressure of the loading spring. As the pin is pulled up it pulls out of the split end of the striker. When the release pin pulls out of the striker the end is free to close and under pressure of the striker spring is forced down out of the constricting well and down onto the primer in the base coupler. The primer will fire into the detonator attached to it causing it to fire.

Modified British Pull Switch

Some photographic evidence indicates that the US had some British "Switch, No. 1, Pull, Mk. I" modified so they could be used with the US base couplers. This seems a simple modification involving enlarging and threading the hole in the collar to fit the M1 Base coupler. No other modification would have been necessary. This would have allowed the British devices to be used with the standard American demolition charges.



British made pull switches modified to accept US Base Couplers.

Firing Device, Pull, M1 (New Style)

Type- Pull

Introduced 1943

Length- 3 3/16 in.

Diameter- 9/16 in.

Body material- Zinc Alloy

The A. C. Gilbert Co. in collaboration with the Engineer Board, redesigned the firing device so that it could be made from zinc die cast alloy. This change simplified production, saved critical brass, include a positive safety and reduced the weight of the device. It was adopted in mid-1943 to replace the old style.

The firing device consists of three main parts, the head, body tube and base coupler.

The head is made to fit inside the main body. It consists of the body, release pin, loading spring and safety pin. The body fits into the main body tube and is crimped in so it cannot be removed. The release pin fits through the bottom up through the top of the body. The loading spring fits over the release pin and is retained by a washer fixed near the bottom. Once the release pin is pushed up, the safety pin fits through holes in the body and pin to hold it in place. A split ring is attached to the end of the release pin to allow a wire to be attached.

The body tube is threaded internally at the bottom and is cast with the constricting well as an integral part. It contains the firing pin and firing pin spring. The firing pin is a single piece turned down to form a striker head and shaft with a ridge on the top end. The top end is split to accept the release pin. The striker and spring are pushed up with the split end passing up through the constricting well to engage the release pin. The release pin pushes the striker end apart so that it cannot pass through the constricting well. The main body tube is cast with a lug on the side. The lug has a hole through it to attach a short piece of cord to act as an anchor. The cord is used to anchor the device in place.

The base coupler contains the primer and screws into the bottom of the body tube.

When the device is set, a pull of 3-5 pounds on the wire will pull the release pin up against the pressure of the loading spring. As the pin is pulled up it pulls out of the split end of the striker. When the release pin pulls out of the striker the end is free to close and under pressure of the striker spring is forced down out of the constricting well and down onto the primer in the base coupler. The primer will fire into the detonator attached to it causing it to fire.



*Firing Device, Pull, M1 (New Style)
Left- WWII issue, Right- Post War issue*

The firing mechanism is painted olive drab. The devices made in WWII are darker than those manufactured post war and are not marked or are marked in yellow. Post war devices have a lighter green wash and have markings in yellow.



*Firing Device, Pull, M1
Painted as a training device*

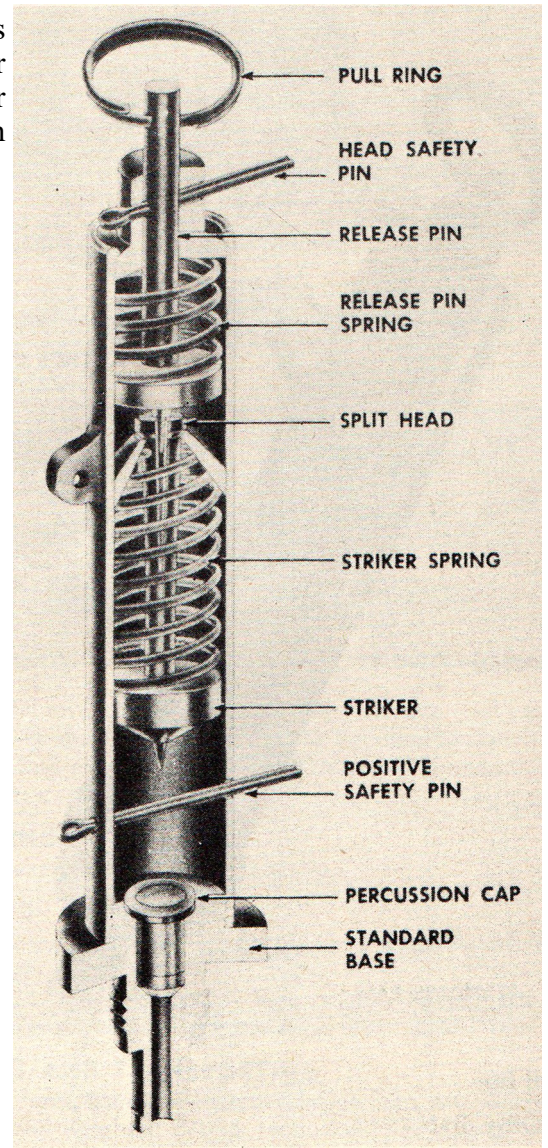

*Firing Device, Pull, M1
internal diagram*

Firing Device, Pull, M2

Type- Pull, Friction

Introduced 1943

Weight- 0.4 oz.

Length- 1 5/8 in.

Diameter- 1/2 in.

In September 1942 Major Erhardt and Mr. J.P. Roysdon of the Engineer board presented the A.C. Gilbert Co. with the project of developing a friction igniter, similar to a German device. The device was to be made of plastic and had to be small, waterproof, and as non-metallic as possible. The company produced many lots with slight revisions before it finally met all the requirements. This was the "Pull Type Firing Device, T2" which was later standardized as the "Firing Device, Pull, Friction, M2". The construction of this device almost eliminated the use of critical war materials. While the device was developed and test lots made by A.C. Gilbert Co. final production was passed to another company.

During development of the T2, there were two other models produced, the T2A and T2B. These differed slightly from the T2 and test lots of 500 each were produced in 1944. Unfortunately no other information is available.

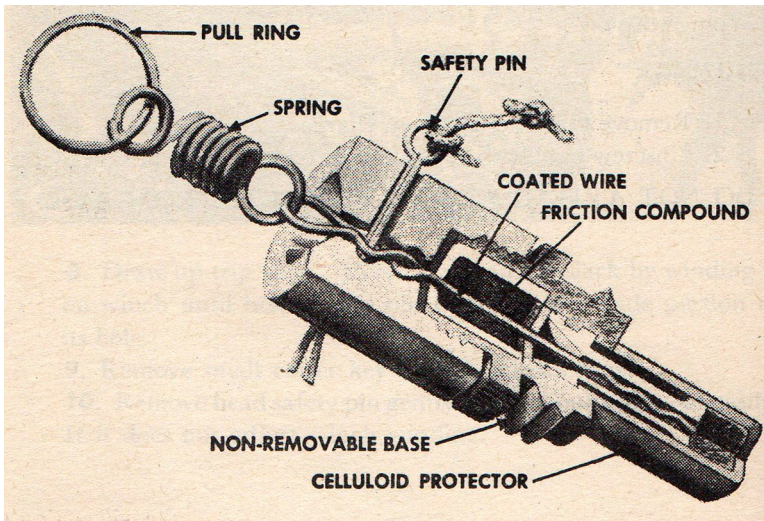

Firing Device, Pull, M2 Internal diagram

The entire device is constructed of black bakelite and a small amount of steel. The body is cylindrical and has a non-removable base coupler on the bottom. The body contains a pellet of friction compound in the top of the base coupler. A steel wire coated with red

phosphorous fits through the top of the body, through the pellet and into the stem of the base coupler. A safety pin fits through the side of the body and through a twisted portion of the wire. A coil spring is attached to the looped end of the wire. The base coupler has a celluloid cup filled with desiccant protecting it.

For use a detonator is crimped onto the base coupler. A slack trip wire is attached to the spring. When a load of 3-9 pounds is applied to the trip wire, it will stretch the spring then snap the friction wire out of the device. That causes the red phosphorous on the wire to pull through the friction compound causing a flame to flash through the base coupler and ignite the detonator. The device is not totally waterproof and should if possible be used where it is protected from moisture.



Unconfirmed, possible T2A or T2B

There is apparently a zinc alloy bodied version. Little is known about this version other than it appears to operate in exactly the same manner. Possibly this is a T2A or T2B.

Firing Device, Pull/Release, M3

Type- Pull/Release
 Introduced 1943
 Length- 4 3/4 in, w/coupling base
 Diameter- 9/16 in.
 Weight- 2 oz.

In February of 1943 Mr. Roysdon of the Engineer Board asked the A. C. Gilbert Company to design a pull firing device that would also fire on release of tension on the trip wire. The company designed the T3 Pull Release firing device, later standardized as the "Firing Device, Pull/Release, M3". The first order for 1000 devices was issued to the company on 3 August 1943.



Firing Device, Pull/Release, M3

The device consists of several parts, the body, ratchet mechanism, striker, striker spring and retaining rod. The body is cast of zinc alloy in a cylindrical form and has a lug on the side for the anchor cord. At the top of the body a reduced diameter head is crimped in that has an elongated safety pin hole in it. The bottom of the body is internally threaded to accept the base coupler. Internally the body has a constriction about 1/4 the way down from the top. The ratchet mechanism is loosely attached to the retaining rod. The retaining rod has a head formed at the bottom end and is long enough to fit slightly through the constriction in the body. The striker is made with a striker head at the bottom, a shaft and slightly wider head at the upper end. The striker is split to form four jaws at the top end. The safety pin is made with a reduced diameter in the centre.

When assembled, the striker and striker spring are forced up from the bottom of the body until the top of the striker fits through the constriction and engages the head on the retaining rod. The safety pin is placed through the elongated hole and retaining rod which keeps the striker from passing fully through the constriction under pressure of the spring. With the top of the striker held at the constriction, the jaws cannot open enough to release the head on the retaining rod. A positive safety pin is then placed through holes in the side of the body below the striker head.

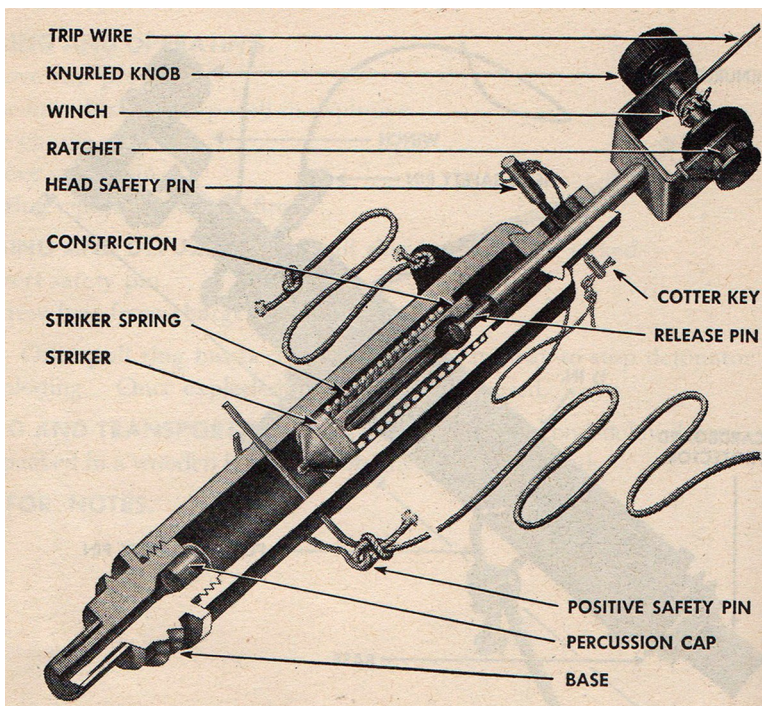

*Firing Device, Pull/Release, M3
 Internal diagram*

The body of the device is either painted olive green or has a green wash applied. The ratchet assembly is black. Markings

are in yellow giving the designation of the device.

When laid, the device is fixed in position with the anchor cord and a trip wire attached to the ratchet mechanism. The wire is then tensioned until the safety pin is about in the middle of the elongated hole. The safety pin can then be removed and the positive safety pin removed last. The wire is taut and when a pressure of 6-10 pounds is applied to the wire it will pull the retaining rod and striker up through the constriction until the jaws on the striker can open enough to release the retaining rod. The striker is then free to move down under pressure from the spring to strike the percussion cap in the base coupler.

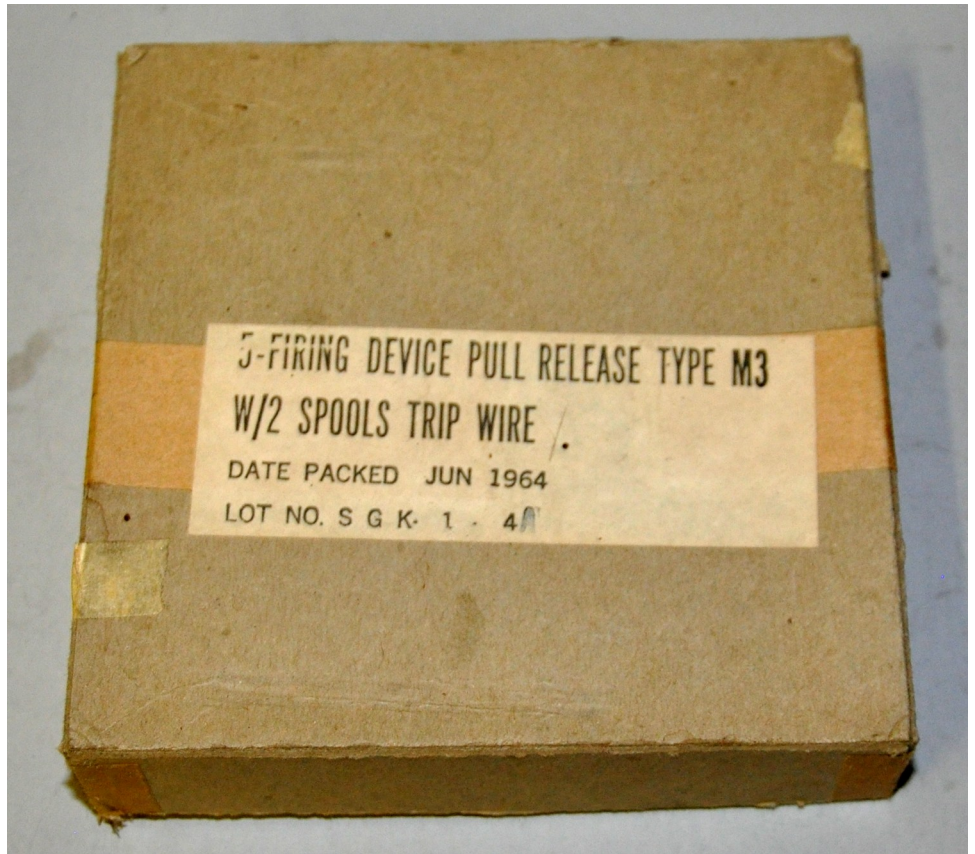

Firing Device, Pull/Release, M3 packaging, dated 1964

Alternatively, if the wire is cut or removed the striker spring will apply pressure to move the striker and retaining rod down through the constriction until the jaws can open and release the striker to move down under pressure of the spring to hit the percussion cap in the base coupler.



*Firing Device, Pull/Release, M3
Inert training device*

Firing Device, Pull, A2

Type- Pull
Introduced 1943
Weight- 1 ounce
Length- 3.25 in.
Diameter- .5 in.

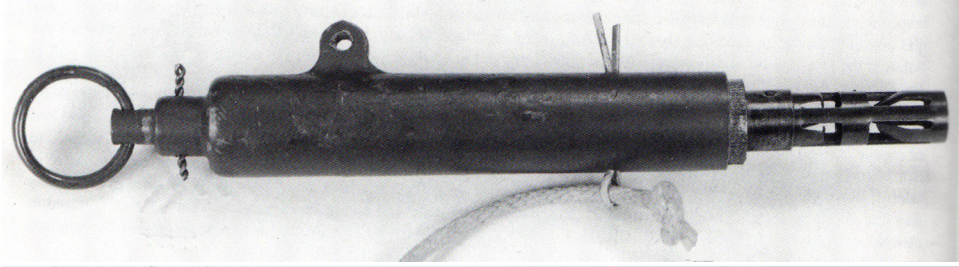

These pull switches were produced by the A. C. Gilbert Co. for OSS use and were also supplied to the British SOE. It appears to be a simple modification of the standard "Firing Device, Pull, M1" to accept a British type spring snout.

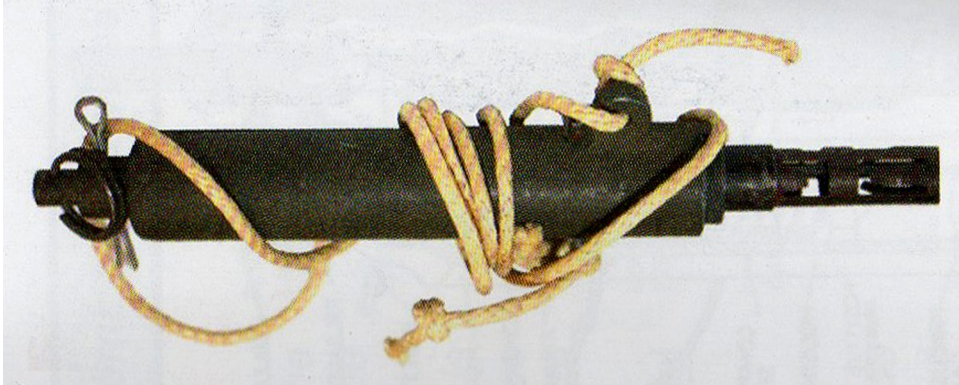

*Firing Device, Pull, A2 (OSS issue)
Note position of fastening lug (perhaps the difference from A1 to A2)*

The firing device consists of three main parts, the head, body tube and spring snout. The head consists of the body, release pin, loading spring and safety pin. The head fits into the main body tube and is crimped in so it cannot be removed. The release pin fits through the bottom up through the top of the body. The loading spring fits over the release pin and is retained by a washer fixed near the bottom. Once the release pin is pushed up, the safety pin fits through holes in the body and pin to hold it in place. A split ring is attached to the end of the release pin to allow a wire to be attached.

The body tube is threaded internally at the bottom and is cast with the constricting well as an integral part. It contains the firing pin and firing pin spring. The firing pin is a single piece turned down to form a striker head and shaft with a ridge on the top end. The top end is split to accept the release pin. The striker and spring are pushed up in the body with the split end going up through the constricting well to engage the release pin. The release pin pushes the striker end apart so that it cannot pass through the constricting well.

The main body tube is cast with a lug on the side. The lug has a hole through it to attach a short piece of cord used to anchor the device in place. Some OSS devices have the lug on the bottom portion of the body rather than the top portion.

The spring snout contains a primer and screws into the bottom of the housing tube. It will accept safety fuse, instantaneous fuse, or a detonator. The spring snout does not screw into normal issue firing devices.

The firing device is painted olive drab with no other markings.

When the device is set, a pull of 3-5 pounds on the wire will pull the release pin up against the pressure of the loading spring. As the pin moves up it pulls out of the split end of the striker. When the release pin pulls out of the striker the end is free to close and under pressure of the striker spring is forced down out of the constricting well and down onto the primer in the spring snout. The primer flashes causing ignition of the fuse or firing the detonator.

Firing Device, Pressure, M1 (Old Type)

Type- Pressure
 Introduced 1942
 Length- 3.5 in.
 Width- 1.5 in.
 Body material- Brass and Steel

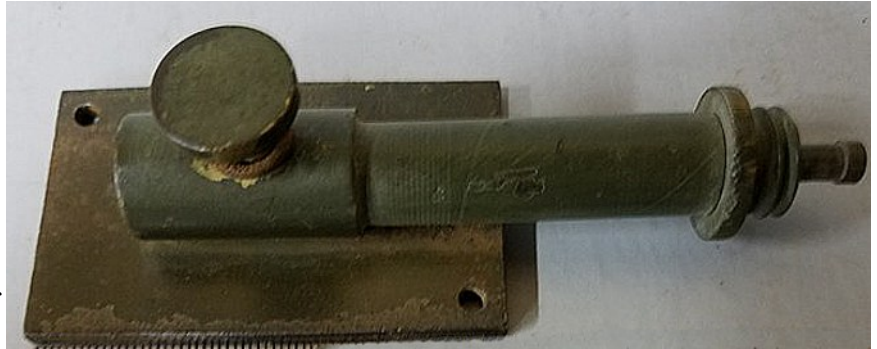

Firing Device, Pressure, M1 (Old Type)

In February 1942 1st Lt. W. L. Erhardt of the Engineer Board, Fort Belvoir, VA gave the task of producing the pressure switch to the A. C. Gilbert Co. The firing device was a copy of the British Pressure switch (No. 2 Pressure, Mk. I) with the exception of using an American style base coupler. The British switch had been introduced in 1941 and was well proven. Several improvements were suggested by the company including using a keyhole type trigger rather than the hardened shear pin. This also had the effect of allowing the firing device to be reused in training. The company produced some 670,000 of this model.

The device consists of a body, pressure head, base plate, and base coupler. The main portions are made of brass with the base plate made of steel. The base plate is 1.5 inches wide and 2.5 inches long with two anchor holes in opposite corners. The body is mounted on the base plate by two flat head bolts through the bottom into the wide end of the body. The body is brass with a wider end that contains the firing mechanism and a thinner barrel portion that contains the striker and spring and is threaded to accept the base coupler. A smaller diameter hole is blind drilled into the head to accept the striker shaft. A larger hole is drilled through the top of the head to accept the pressure head. The pressure head is made of brass and has the bottom machined down to a trigger pin with a keyhole in it.

When assembled, the striker and spring are placed into the body barrel, the pressure head and spring are placed into the hole in the head and pressed down so the large portion of the keyhole lines up with the small hole in the head. The striker is forced against the pressure of the spring into the small hole and through the hole in the pressure head. When pressure is released on the head, the spring forces the head up engaging the small end of the keyhole with the groove in the striker preventing the striker from moving. A safety clip is engaged between the head of the pressure head (over the spring) and the body preventing the head from moving down.

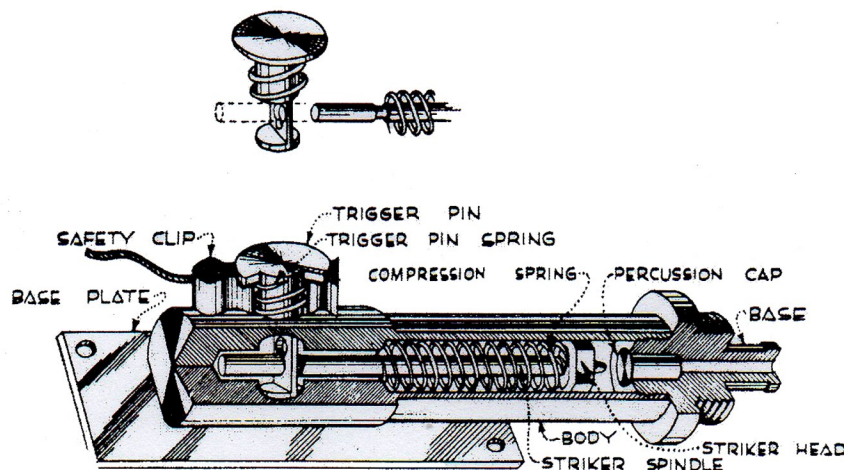

Firing Device, Pressure, M1 (Old Type)
Internal diagram

When laid and the safety clip is removed, a pressure of 20 pounds or more will cause the pressure head to move down bringing the large end of the keyhole in line with the striker shaft disengaging it from the striker groove. This allows the striker spring to reassert itself and push the striker forward until it strikes the percussion cap in the base coupler. The cap fires and initiates the detonator attached to the base coupler and in turn the main charge.

Firing Device, Pressure, M1 (New Type)

Type- Pressure
Introduced 1942
Length- 3.5 in.
Height- 1.125 in.
Width- 1.5 in.
Body material- Zinc alloy

The A. C. Gilbert Co. in collaboration with the Engineer Board, redesigned the firing device in August 1942 so that it could be made from die cast zinc alloy. This change simplified production, saved critical brass, include a positive safety and reduced the weight of the device. It was adopted in mid-1943 to replace the old style. The first contract for this version was for 685,000 firing devices.



Firing Device, Pressure, M1 (New Type) and extension

The device consists of a body, pressure head and base coupler. The body is die cast zinc alloy made in a single piece. It has a basically tubular body with a flattened base for about half the length. Protruding out from the base are three lugs that are used to fasten the device in place. A hole in the top of the body fits the pressure head. The striker which has a firing pin head at one end and a groove in the shaft at the other fits with the striker spring inside the body. The pressure head has a flat top with a shaft on the bottom. There is a keyhole in the lower portion of the shaft. The base coupler is the standard M1 base coupler.

When assembled, the striker and spring are put into the body and forced into the body so that the shaft of the striker fits into a small hole in the back that connects with the hole in the top of the body. The pressure head with spring are pushed down so the shaft of the striker fits through the large upper hole in the keyhole. Once the shaft of the striker is pushed through the pressure head is released so that the small portion of the keyhole engages in the groove in the striker shaft. This holds the striker back in the cocked position. A safety clip fits over the spring on the pressure head preventing its downward movement. A positive safety pin is fitted through holes in the side of the body in front of the striker.



Firing Device, Pressure, M1 (New Type) with extension rod installed

The device is supplied with an extension rod. The rod consists of a length of threaded rod mounted on a cup and an internally threaded tube.

The cup press fits onto the pressure head. The extension provides between 1.25 and 2.25 inches of extension.

When laid and the safety pin and clip are removed, a pressure of 20 pounds or more will cause the pressure head to move down bringing the large end of the keyhole in line with the striker shaft disengaging it from the striker groove. This allows the striker spring to reassert itself and push the striker forward until it strikes the percussion cap in the base coupler. The cap fires and initiates the detonator attached to the base coupler and in turn the main charge.

Firing Device, Pressure, M1A1

Type- Pressure

Introduced 1943

Length- 3.5 in.

Height- 1.125 in. wo adapter

Width- 1.5 in.

Body material- Zinc alloy

In 1943 The A. C. Gilbert Co. modified the M1 pressure Firing Device to add a three pronged adapter to the pressure head. The three pronged head was copied from a German mine igniter and allowed better camouflage for the device. The modifications were minor and were done quickly.

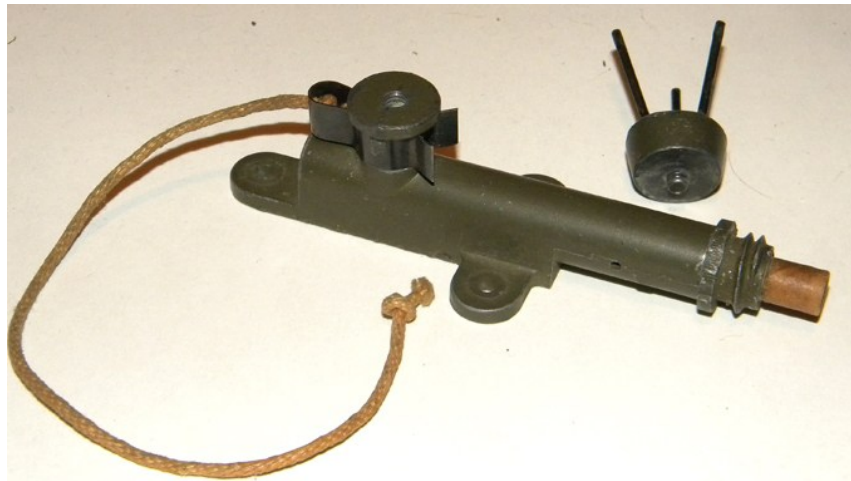

Firing Device, Pressure, M1A1 and three pronged adapter

The device consists of a body, pressure head and base coupler. The body is die cast zinc alloy made in a single piece. It has a basically tubular body with a flattened base for about half the length. Protruding out from the base are three tabs that are used to fasten the device in place. A hole in the top of the body fits the pressure head. The striker which has a firing pin head at one end and a groove in the shaft at the other fits with the striker spring inside the body. The pressure head has a flat top with a shaft on the bottom and a threaded hole in the top. There is a keyhole in the lower portion of the shaft. The base coupler is the standard M1 base coupler.

When assembled, the striker and spring are put into the body and forced into the body so that the shaft of the striker fits into a small hole in the back that connects with the hole in the top of the body. The pressure head with spring are pushed down so the shaft of the striker fits through the large upper hole in the keyhole. Once the shaft of the striker is pushed through the pressure head is released so that the small portion of the keyhole engages in the groove in the striker shaft. This holds the striker back in the cocked position. A safety clip fits over the spring on the pressure head preventing its downward movement. A positive safety pin is fitted through holes in the side of the body in front of the striker.

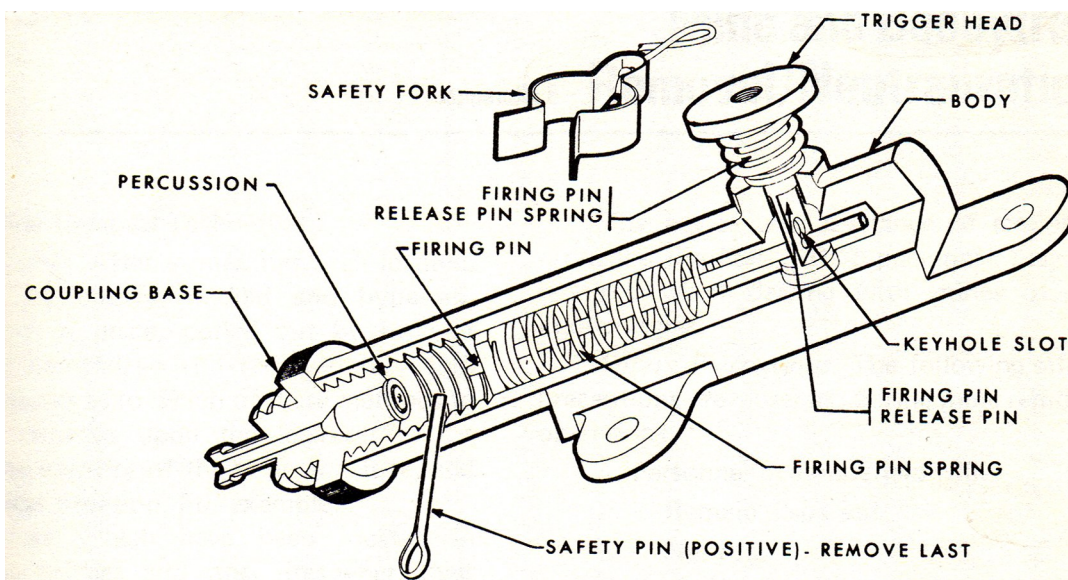

Firing Device, Pressure, M1A1 Internal diagram

The device is supplied with an extension rod and three pronged adapter. The rod consists of a length of threaded rod and an internally threaded tube. The three pronged adapter has a base with three wire prongs attached by a bolt to the top. The adapter can be screwed

can be screwed directly onto the pressure head or can be attached to the extension rod which is then screwed onto the pressure head. The adapter is 1 1/4 in. high, the extension rod provides between 1 1/4 and 1 5/8 inch extension.

When laid and the safety pin and clip are removed, a pressure of 20 pounds or more will cause the pressure head to move down bringing the large end of the keyhole in line with the striker shaft disengaging it from the striker groove. This allows the striker spring to reassert itself and push the striker forward until it strikes the percussion cap in the base coupler. The cap fires and initiates the detonator attached to the base coupler and in turn the main charge.



Firing Device, Pressure, M1A1 with extension rod and three pronged adapter

Firing Device, Pressure, A1

This was a copy of the British “No. 5, Pressure, Mk. I” switch. The A.C. Gilbert Co. was contracted by the OSS to produce this device. They modified the design so as to cut out the hinge rivets and use part of the case embossed out to form the hinge. All changes were authorized by Major S. Lucy of the OSS. Once the changes were made the device was accepted as the “Firing Device, Pressure, A2”.

Firing Device, Pressure, A2

Type- Pressure
Introduced 1943

The A. C. Gilbert Co. produced 9100 of these devices in 1943. Considerable difficulty was encountered as the British requirements differed from the American requirements. To produce a device to meet one set of requirements was not a problem, but meeting both sets was difficult. The problems did not present themselves until the devices had been produced and sent to the field. After considerable experimentation the problems were solved and the adjusted device was accepted as the “Firing Device, Pressure, A3”. It is unknown what changes were made to the device.

Firing Device, Pressure, A3

Type- Pressure
Introduced 1944
Weight- 2 oz.
Length- 2.75 in.
Width- 1.25 in.
Height- .75 in.



This is a US modified copy of the British “Switch, No. 5, Pressure, Mk. I”. These were produced on OSS contracts by the A. C. Gilbert Co. at the request of the British as they could not produce enough to meet all their needs. The American version differs slightly from British made switches.

The switch consists of a steel case with a hinged steel lid fitting inside the case. An alloy body is fixed inside the case by a countersunk bolt. The end of the body is threaded to accept a spring snout. There are two holes in the bottom of the case for use in securing the switch. Two studs on the bottom inside of the case keep the sear springs in position. The lid has a centre threaded hole to screw an extension into. The striker is formed with a shoulder and firing pin on one end and a detent on the other. The sear is formed of steel and has two studs riveted on to correspond with the studs on the case to retain the sear springs. The pressure points on the sear project up on either side of the body. A safety pin passes through the case, body, and striker to ensure the device will not fire when it is in position.

An extension rod is made in two parts, a socket that screws into the top of the lid and a rod that screws into the socket. The extension is adjustable in height by about one inch by varying the amount that the rod is screwed into the socket. If a shorter extension is required, the socket may be used without the rod. The extension rod on the US manufactured device is thicker than the British version

The firing device is painted olive green with no other markings.

When the switch is assembled, the striker and striker spring are inserted in the end of the body with the detent facing down. The striker is pressed back until the detent engages the sear and holds the striker in the cocked position. The safety pin is then passed through the holes in the side of the body to make the switch safe.

The pressure necessary to operate the device varies with the position the pressure is applied on the lid. At the farthest from the hinge pin it requires a pressure of 21 pounds, at the centre a pressure of 50 to 60 pounds is required. When pressure is applied to the switch the lid presses down on the sear, when the sear is pressed down it disengages from the detent allowing the striker to fly forward under pressure of the striker spring. The firing pin hits the percussion cap and fires the charge.

Firing Device, Release, M1

Type- Release
Introduced 1943
Weight- 5.3 oz.
Length- 2.25 in. w/o base coupler
Width- 2 in.
Height- 2 in.

This firing device was introduced during WWII. It is strictly an American design not taken or designed from any devices in service with anyone else. At first glance, it seems an overly large but it is designed to be the same size as the standard US Army ½ and 1 pound demolition blocks. One of the manufacturers of this device was the Geometric Stamping Co. of Euclid Ohio.



Firing Device, Release, M1 (old style)

The body of the device is a stamped sheet metal box with rounded edges. One end is open, the other closed with a tube spot welded on and internally threaded to hold the base coupler. The other end is closed by a removable stamped sheet metal cap. The firing pin is inserted in a small hole in the centre of the stem and held on by a press fit washer. The firing hammer mechanism is riveted inside just above the stem. On the outside of the device, held on by the same rivets as the firing mechanism, is a bracket for the safety pin and release plate. The release plate is formed of sheet metal with a tail, plate and a portion formed on the bottom to fit into the bracket. There are two holes punched in either side of the device opposite each other. There are small tubes inserted in the holes that leave a space between them. These holes are used for a positive safety in that a nail or rod inserted through the holes will block the travel of the firing hammer before it can strike the firing pin.

There are mounting brackets spot welded onto the bottom of the body. The earlier firing devices have a mounting bracket ¾ inch wide at 90 degrees from the stem with a single hole on either end. These are bent up around the device until required. A later version has the mounting bracket turned 90 degrees and is angled in appearance. At the back end (over the end cap) is a single hole, at the other end, which is bent up around the stem there are two holes. Other than the mounting brackets, the devices are identical.



Firing Device, Release, M1 (new style)

When the device is assembled, the tail of the release plate fits through a slot in the top of the body. The tail engages in a slot in the cocked firing hammer. The release plate is then pushed down into the bracket and the safety pin inserted to hold the device in the cocked position. The base coupler screws into the stem and pushes the loose firing pin

back into the device.

The devices are unpainted but do have some type of protective coating. On the earlier devices "This side up" is printed on the top of the release plate. On later devices, it is stamped into the release plate. No other markings have been noted.

A weight of at least two pounds is required to hold the release plate down. When the weight is removed the firing hammer, under pressure of its spring, pulls down on the tail of the release plate. Once it has travelled far enough, the plate disengages leaving the hammer free to rotate under pressure of the spring until it strikes the firing pin. It forces the firing pin forward to hit the percussion cap in the base coupler which fires and causes the attached detonator to fire.

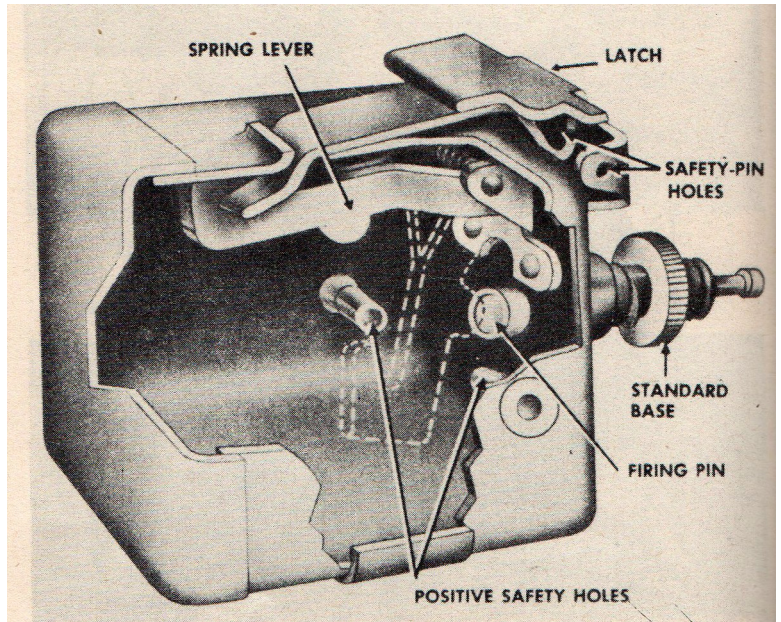

Firing Device, Release, M1 (old style) internal diagram

Firing Device, Release, M5

Type- Release
Introduced 1944
Weight- 1.5 oz.
Length- 1 ¾ in.
Width- 1 in.
Height- ¾ in.

In June of 1943, Captain Terbert of the Engineer Board gave the A. C. Gilbert Co. a model of a release device and asked them to incorporate some changes to the model and make samples. Once the samples were produced and approved a number were made for training. During training it was found that further changes and improvements were required. Several revised models were produced until one finally satisfied all the requirements of the Engineer Board. The final model was standardized as the "Firing Device, Release, M5"

The device is made of sheet steel and is press formed into an open topped rectangular box. On the bottom of the box is a hole threaded to accept the base coupler. The release plate is hinged on the top of the box, at the opposite end to the hole in the bottom. The release plate is bent to form a hinge at one end and near the other end is bent to form a slot for the safety pin. A piece of spring steel is riveted onto the release plate so that it will put pressure on the safety pin to hold it in

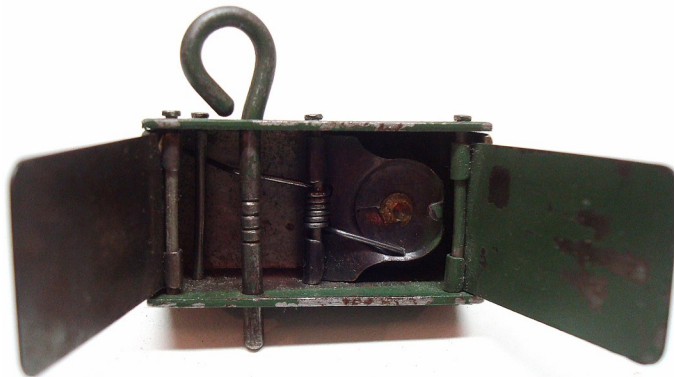
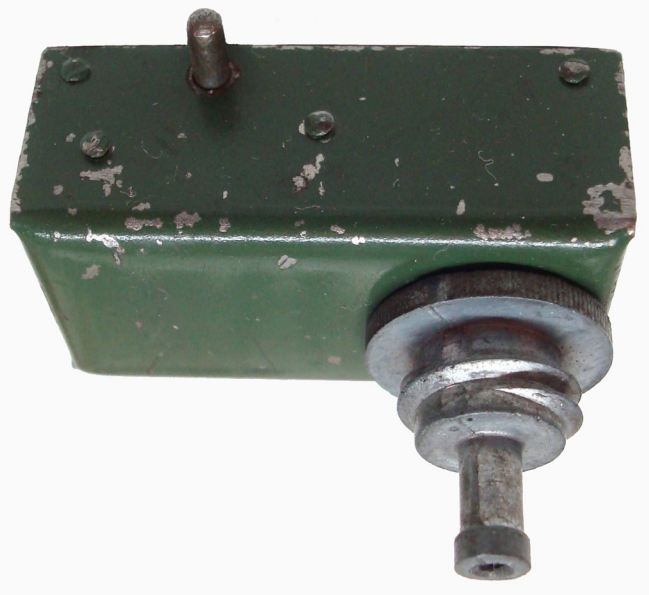

These two photographs show a device, similar to the M5 but with differences in the striker and the use of two top release flaps. This may be (unconfirmed) one of the early development versions for the M5 device.

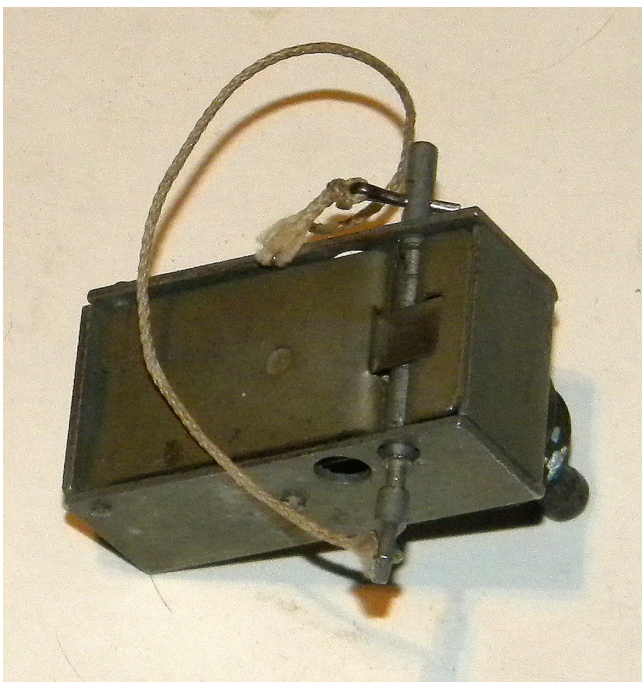

place. A spring loaded striker is hinged in the middle of the box so that when the striker rotates the striker point will strike the percussion cap in the base coupler. There are holes in the side of the box, one set for the safety pin that line up with the slot in the release plate, the other larger set allow a pin or nail to be inserted to block the travel of the striker. The safety pin has two grooves turned into it that will slightly engage the sides of the mechanism and make removal more difficult if the release plate is not fully down. A small cotter pin through one end of the safety pin prevents accidental removal.

The device is not painted but has a greenish wash applied.

A minimum weight of 5 lbs is required to hold the release plate down when laid. When the weight is

Firing Device, Release, M5

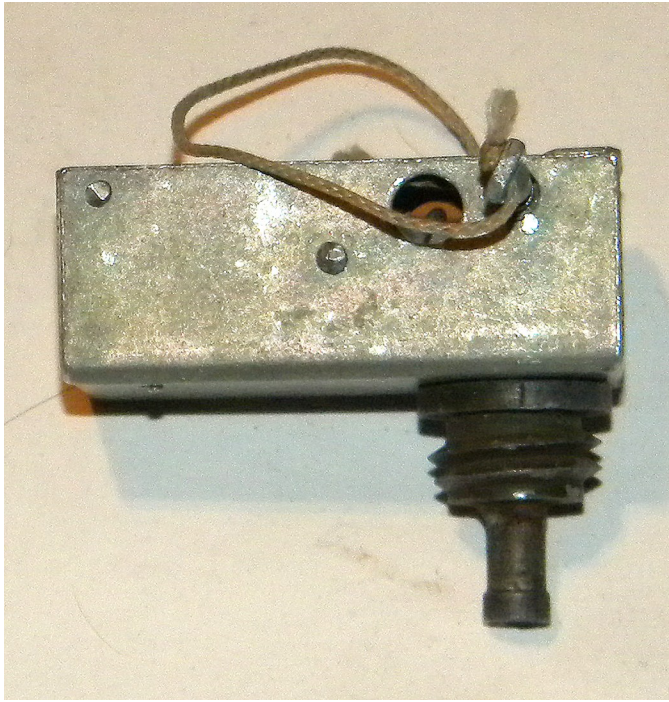

Firing Device, Release, M5

removed the striker spring reasserts itself and causes the striker to rotate. The rotating striker pushes up on the release plate until it is pushed out of the way and the striker is free to completely rotate and hit the percussion cap in the base coupler. The percussion cap will cause the detonator attached to the base coupler to fire.

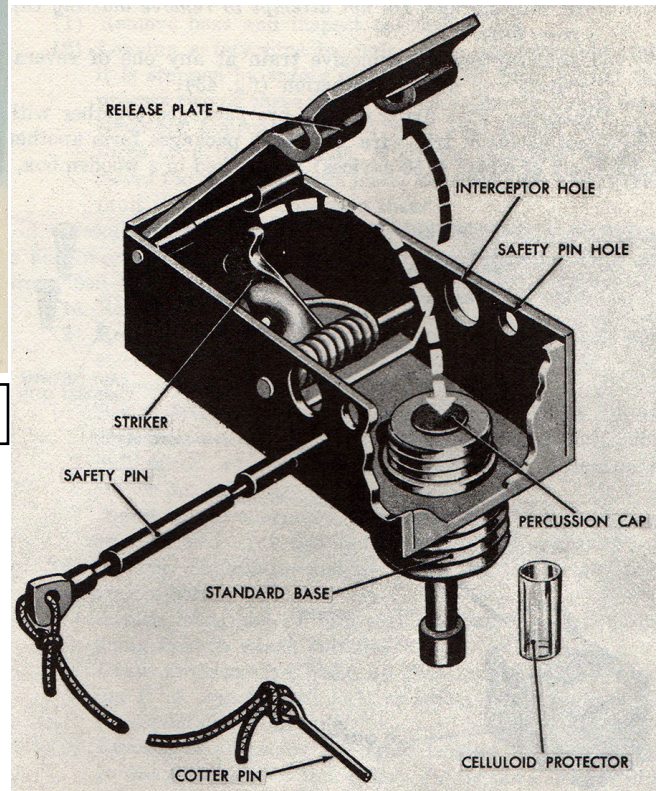

Firing Device, Release, M5 internal diagram



Firing Device, Release, M5 packing

Firing Device, Release, A1

Type- Release
Introduced 1943
Length- 3.5 in. w/o snout
Width- 9/16 in.
Height- 5/8 in.

This device is a direct copy of the British “Switch, No. 6, Release, Mk. I”. It was produced by A.C, Gilbert Co. in the US on instruction from the OSS. Some were made for the British SOE and the remainder for use by OSS.

Firing Device, Release, A2

Type- Release
Introduced 1943
Weight- 2 oz.
Length- 4.5 in. with snout
Width- 5/8 in.
Height- 5/8 in.



This is a modification of *Firing Device, Release, A2* “Firing Device, Release, A1”. At this time the actual differences between the two devices is unknown.

The switch consists of an alloy body threaded at one end to receive a spring snout. The other end is flattened to allow it to be inserted into narrow openings. A hole drilled in the flattened end enabled the switch to be fastened in position. A lid is hinged at the threaded end and fits over the body. The sear is hinged at the opposite end. The striker is formed with a shoulder and firing pin at one end and a detent cut on the other. A safety pin hole is drilled through the body and another through the striker. There are minor differences between the British and US devices. The lid hinge is slightly squarer, the axis pin is larger and the US spring snout is slightly different. US devices normally have a rubber sheath over the spring snout.

When assembled, the striker and striker spring are inserted in the threaded end with the detent facing up. The striker is pushed back until the sear engages in the detent and holds the striker. The safety pin must be put in place or the switch will operate. The safety pin is the only thing holding the switch in the cocked position at this point.

The firing device is painted olive green with no other markings.

When the switch is set in position and a weight of 3.5 lbs. minimum is applied to the lid, it forces down on the lid and sear forcing the striker back slightly releasing the safety pin. The safety pin can then be easily removed without force. A seven pound weight is the minimum weight recommended to hold the switch.

When the restraining weight is removed, the striker stem pushes against the sear causing it to rotate which pushes up the lid. When the sear has rotated enough, the striker is released to fly forward under pressure of its spring to strike the cap in the snout. The cap fires and either fires the detonator or ignites the fuse attached.

Firing Device, Combination, M1

Type- Combination
 Introduced- 1942
 Length- 3.25 in.
 Diameter- Head 3/4 in.
 Tube 9/16 in.

In April 1942 Major Erhardt of the Engineer Board supplied the A. C. Gilbert Co. with drawings of a pull type firing device with a swiveling head. The device as designed had some problems but through testing and modifications was made to work as required. Also, with a simple modification it would operate not only by a pull, but by pressure as well. The changes and modifications were accepted by the Engineer Board who designated the device as "M1 Combination Firing Device". The device was designed for use by the Ordnance Department in the M2 and M3 Anti-Personnel mines. The device was to be made of brass and indeed the first order of 150,000 were made of brass. While the company was producing the first



Firing Device, Combination, M1

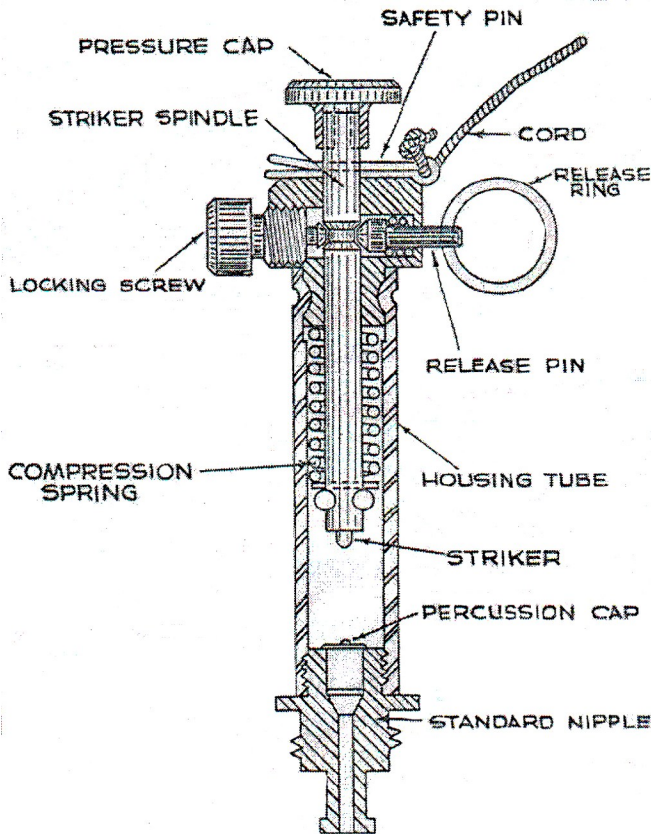

Firing Device, Combination, M1 internal idagram

order they redesigned it to enable it to be made of cast zinc alloy and steel eliminating the use of a critical material.

The device consists of two main parts, the body tube and the head. The body tube is a tube, internally threaded at the bottom end to accept the standard base coupler. The head consists of a cylindrical body reduced at the bottom to fit into the top of the body tube. There is a groove in the reduced portion that allows the body tube to be crimped into it, tight enough to retain it, but still allowing it to rotate. The head is drilled through top to bottom to allow the striker shaft to pass through. One side of the head has a threaded hole to fit a locking screw and the opposite side has a hole to fit the release pin and spring. A split ring is attached to the release pin. The striker has a firing pin at the bottom end and near the top end a groove around the shaft. Above the groove is a hole to fit the safety pin. A pressure cap is press fitted to the top of the striker shaft.

When assembled the striker and striker spring are pushed up from the bottom with the shaft fitting through the hole in the head until the safety pin can be fitted. The release pin is spring loaded

and pushes into the groove in the striker shaft. The locking screw is screwed in to hold everything in position. The pressure head is then pushed onto the end of the striker shaft.

When ready for use, the locking screw is backed off so it no longer engages in the groove of the striker shaft. The safety pin is then removed arming the device. If the safety pin binds as it is being removed it is likely that the release pin is not properly engaged and the device is dangerous. When armed, a pull on the release pin of 3-6 pounds will withdraw the release pin from the groove and allow the striker under pressure of the spring to fly down to hit the percussion cap in the base coupler. Alternatively, a pressure of 20 or more pounds on the pressure head is sufficient to push the release pin back against its spring and release the striker. As the striker moves down the pressure head will be forced off the striker shaft.

The original device did not have a positive safety. A modification was made that moved the safety pin from the top of the striker to holes drilled 1/8 to 3/16 inch below the bottom of the assembled striker. For devices already in the field, it was permissible to do the modification in the field, further manufacture would have the modification included.

The device could be used with standard anti-personnel mines, grenades and the bangalore torpedo.

Fuze, Mine, Anti-personnel, M2/M2A1

When the Combination firing device, M1 is used in the M2 Anti-personnel mine, it is fitted with an igniter crimped onto the base coupler. The assembly is then designated as "Fuze, Mine, Anti-personnel, M2". The device with the modification to the safety pin are designated as M2A1.

Fuze, Mine, Anti-personnel, M3/M3A1

When the Combination firing device, M1 is used in the M3 Anti-personnel mine, it is fitted with a detonator crimped onto the base coupler. The assembly is then designated as "Fuze, Mine, Anti-personnel, M3". The device with the modification to the safety pin are designated as M3A1.

Combination Firing Device, Mk. 1 Mod. 0

Type- Pull/Pressure/Release
 Introduced prior to 1944
 Weight-
 Length- 4 3/16 in.
 Width-
 Height-

This is a US Navy device, introduced during WWII. Depending on how it is set it can operate as a pressure, pull or release device.

The device consists of a body, trigger pin, firing pin, base, bail, trigger eye and knurled nut. The body is constructed of brass in a cylindrical shape. The main body is flattened on one side and has two holes drilled through it. One hole is from the top opposite the flattened area, the other through the end. One end has a larger hole bored and threaded to accept a barrel externally threaded to screw into the main body and with the other end internally threaded to accept a standard base coupler. The base is brass and has three holes, the two outer holes are countersunk and the central hole is not. There are also four mounting holes in the corners of the base. The central hole lines up with the hole bored through the body and the other two are used to bolt the base onto the main body. The bail is attached centrally on the main body. The trigger pin has two slots connected by a central hole and a threaded hole in the bottom. The top of the trigger pin has a flat trigger button screwed on the top. The firing pin has a striker head at one end and is threaded on the opposite end. A circumferential groove in the middle of the firing pin shaft fits the slots in the trigger pin. The knurled nut fits on the threaded end of the firing pin. The trigger eye fits up through the base to screw into the bottom of the trigger pin. There is no positive safety pin, the device is held safe by the knurled nut.

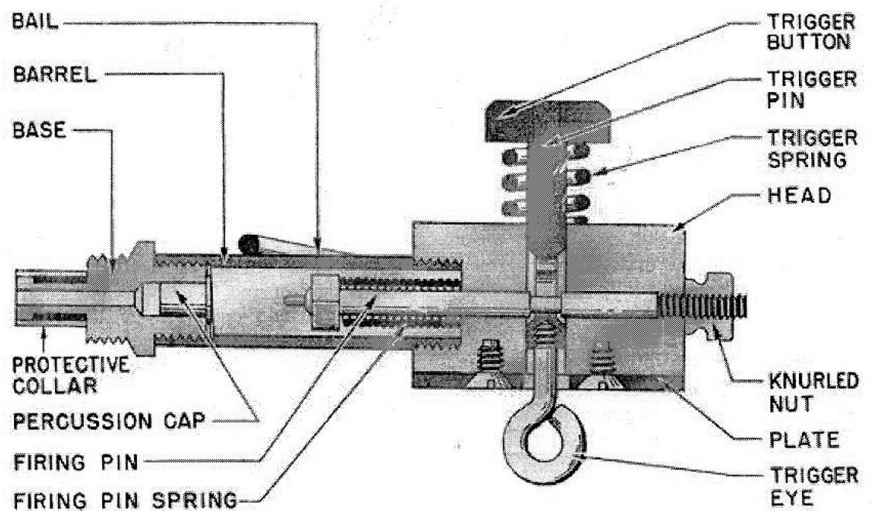

*Combination Firing Device, Mk. 1 Mod. 0
 Internal diagram*

When assembled, the trigger pin fits through the top hole in the main body with a trigger spring fitted over it. The firing pin and firing pin spring then fit through the barrel with the shaft passing through the trigger pin and is held in position by the knurled nut.

For use as a pressure device the trigger pin is in the "up" position with the groove in the striker fitting into the bottom slot in the trigger pin. When the knurled nut is removed and pressure applied on the trigger button, it will push down against pressure of the trigger spring and bring the centre hole in the trigger pin in line with the striker shaft allowing the striker under pressure of the striker spring to move forward to hit the cap in the base coupler.

For use as a release device the trigger pin is in the "Down" position with the groove in the striker fitting into the upper slot in the trigger pin. A weight of 31 pounds is required to hold the trigger pin down against the pressure of the trigger spring. When the knurled nut is removed and pressure removed from the trigger button, it will push up by the pressure of the trigger spring and bring the centre hole in the trigger pin in line with the striker shaft allowing the striker under pressure of the striker spring to move forward to hit the cap in the base coupler.

For use as a pull device it is anchored at one end by the bail and the trigger eye screwed into the bottom of the device. The trip wire is attached to the trigger eye. The trigger pin is in the "up"

position with the groove in the striker fitting into the bottom slot in the trigger pin. When the knurled nut is removed and pressure applied to the trip wire it will pull against pressure of the trigger spring and bring the centre hole in the trigger pin in line with the striker shaft allowing the striker under pressure of the striker spring to move forward to hit the cap in the base coupler. It can also be used as a tension release device by applying enough pressure on the trip wire to pull the trigger pin through into the "Down" position. When the tension on the wire is released the trigger spring will apply pressure to the trigger pin pulling it up until the striker shaft lines up with the central hole and the striker is released to hit the percussion cap.

Demolition Firing Device, Mk. 1 Mod 1

Type- Pull/Pressure/Release

Introduced 1944

Weight-

Length- 4 3/16 in.

Width-

Height- 2 5/8 in Max

This is a US Navy device modified from the earlier Mk. 1 Mod 0 device. Depending on how it is set it can operate as a pressure, pull or release device.

The device consists of a body, trigger pin, firing pin, base, bail and knurled nut. The body is cast of brass as a single piece

incorporating the main body, barrel and base. The body has two holes drilled through it. One hole is from the top, the other through the end. The end of the barrel is internally threaded to accept a standard base coupler. The bail is attached centrally on the main body. There are four mounting holes in the base. The trigger pin has two slots connected by a central hole and a threaded hole in the bottom.

The top of the trigger pin has a flat trigger button screwed on the top. The firing pin has a striker head at one end and is threaded on the opposite end. A circumferential groove in the middle of the firing pin shaft fits the slots in the trigger pin. The knurled nut fits on the threaded end of the firing pin. There is a positive safety pin that fits through holes in the side of the barrel blocking travel of the striker.

There are two attachments supplied with each device. The ratchet reel replaces the trigger eye so that a more

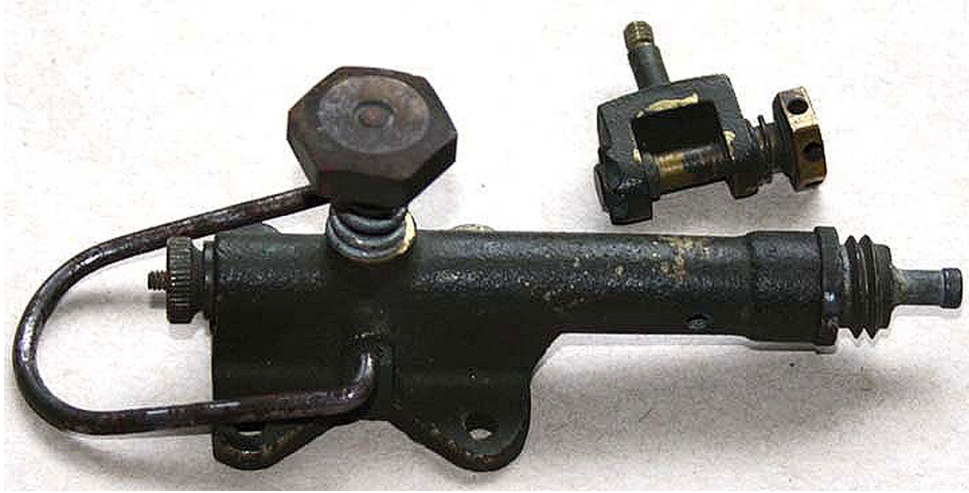

Combination Firing Device, Mk. 1 Mod. 1

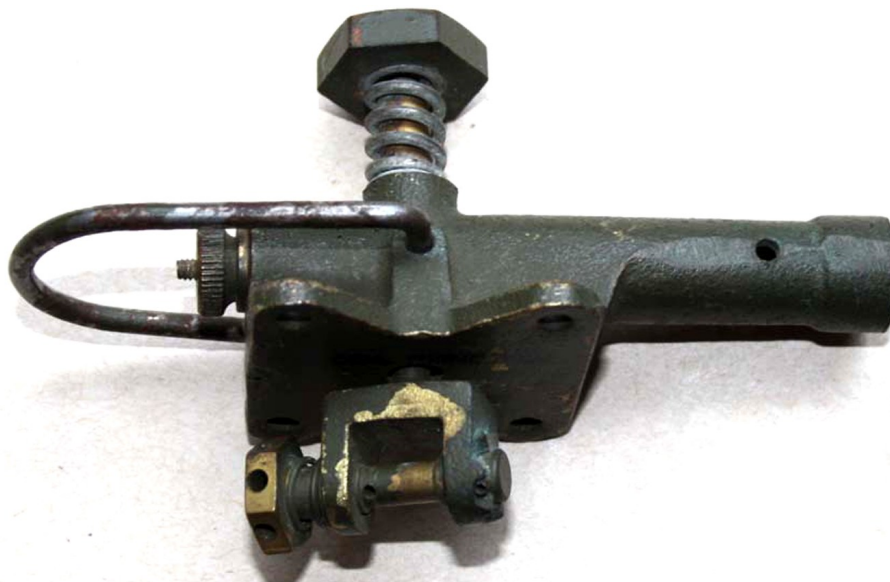

Bottom of device showing ratchet reel in place

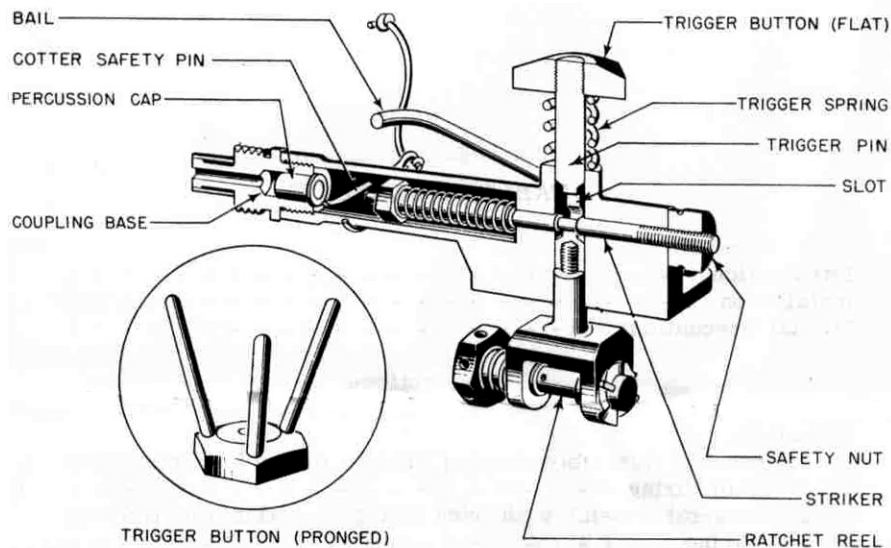

accurate adjustment of the trip or tension wire can be made. In addition there is a three pronged trigger button that can replace the flat button.

When assembled, the trigger pin fits through the top hole in the main body with a trigger spring fitted over it. The firing pin and firing pin spring then fit through the barrel with the shaft passing through the trigger pin and is held in position by the knurled nut.

For use as a pressure device the trigger pin is in the "Up" position with the groove in the striker fitting into the bottom

*Demolition Firing Device, Mk. 1 Mod 1
Showing device set for pressure or pull firing*

slot in the trigger pin. When the knurled nut is removed and pressure applied on the trigger button, it will push down against pressure of the trigger spring and bring the centre hole in the trigger pin in line with the striker shaft allowing the striker under pressure of the striker spring to move forward to hit the cap in the base coupler.

For use as a release device the trigger pin is in the "Down" position with the groove in the striker fitting into the upper slot in the trigger pin. A weight of at least 11 pounds is required to hold the trigger pin down against the pressure of the trigger spring. When the knurled nut is removed and pressure removed from the trigger button, it will push up by the pressure of the trigger spring and bring the centre hole in the trigger pin in line with the striker shaft allowing the striker under pressure of the striker spring to move forward to hit the cap in the base coupler.

For use as a pull device it is anchored at one end by the bail and the ratchet reel screwed into the bottom of the device. The trip wire is attached to the ratchet reel. The trigger pin is in the "up" position with the groove in the striker fitting into the bottom slot in the trigger pin. When the knurled nut is removed and pressure applied to the trip wire it will pull against pressure of the trigger spring and bring the centre hole in the trigger pin in line with the striker shaft allowing the striker under pressure of the striker spring to move forward to hit the cap in the base coupler. It can also be used as a tension release device by applying enough pressure on the trip wire to pull the trigger pin through into the "Down" position. When the tension on the wire is released the trigger spring will apply pressure to the trigger pin pulling it up until the striker shaft lines up with the central hole and the striker is released to hit the percussion cap.



*Demolition Firing Device, Mk. 1 Mod 1
Packing tin.*

Firing Device, Demolition, Multi Purpose, M142

Weight- 1.2 oz.
Length- 2.25 in.
Width- 1.6 in.
Height- 1.1 in.
Body Material- Plastic

The M142 was introduced into American service in about 1972. It is a direct copy of the Australian "Firing Device, Combination, F1A1". The devices were in fact manufactured in Australia for the American forces.

The device is a compact unit capable of initiating a boobytrap via Pull, Pressure, Release, or Tension Release depending on how it is set. The device will operate under a pressure of 11.3 kg, a pull of 3.2 kg, or a release of pressure or tension of 1.1 kg.



Firing Device, Demolition, Multi Purpose, M142

The device is made of plastic in a basically cylindrical form. There are lugs and recesses molded onto the body that allows it to be screwed, nailed or wired in almost any position. A slot in the top of the body accepts the sear plate that is held in position by two pins, one with a round head, one with a square head. A positive safety pin fits through the barrel of the body preventing the striker from hitting the percussion cap. An alternative set of holes for the positive safety are located at 90 degrees from the normal holes. The striker is made of aluminum with a plastic four pronged guide and spring stop near the point. The rear portion of the striker has a groove that engages the sear. A striker spring fits over the striker. The striker and spring fit into the body compressing the spring until the sear on the bottom of the sear plate engages the groove in the striker.

The device is issued in a round plastic case containing everything required to set the device in any mode. Contained within the case is the device, roll of steel trip wire containing 15 metres of wire, a strip of tape containing screws and nails, a tension release attachment, coupling body and an instruction sheet. The coupling base is also issued separately. Early issues of the device were packed in round tin boxes.

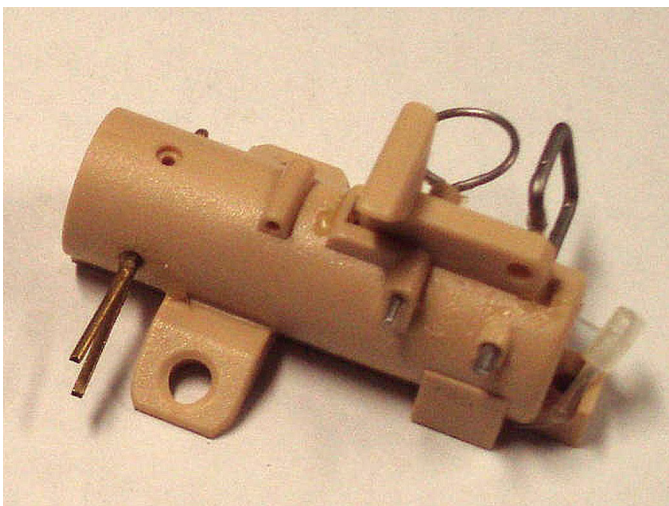

*Firing Device, Demolition, Multi Purpose, M142
in tan coloured plastic.*

The firing device is normally used with the Coupling base but the US M1 Base coupler can also be used.

The device is made of olive green plastic, as is the coupling body. The coupling bodies have a yellow or brown band around the centre.

The mode of use determines which pins are taken out to set the device. For use as a release device, the round headed pin is removed. For use as a pressure device, the square headed pin is removed, for use as a pull device, the square headed pin is removed, and for use as tension release it must be fitted with the attachment and have the round headed pin removed. It should be



Two versions of packing containers. On the left is the earlier style, made of tin, on the right is the later plastic version.

noted that the two pins are not interchangeable as they are made from different gauges of wire with corresponding holes.

At some point some examples of the M142 were made in tan plastic. Containers were also made of tan plastic with markings in black. The lot number indicates they were made in the UK by "Mondial Defence Systems Limited". It is unknown if these versions were ever used by the US or anyone else.

FIRING DEVICE, DEMOLITION MULTIPURPOSE MI42



LONG NAILS AND SCREWS
FOR SOFT WOOD

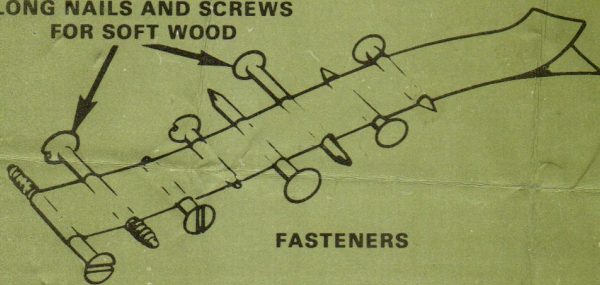

REEL TRIP WIRE
WITH 50 FT. OF WIRE

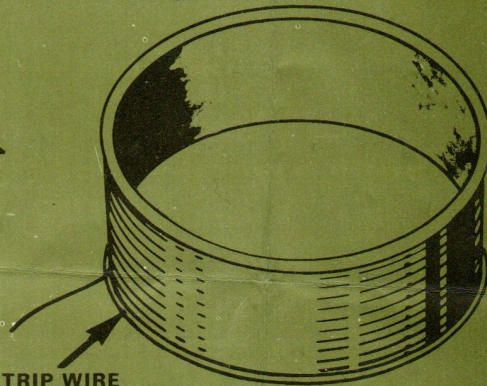

FOR SETTING INSTRUCTIONS SEE OTHER SIDE.

IF RESETTING, ENSURE THAT THE USERS EYE IS NOT IN LINE WITH THE EJECTIONS OF THE STRIKER.
WHEN SECURING TO IRREGULAR SURFACE DO NOT BEND EARS OTHERWISE DISTORTION AND MALFUNCTION MAY OCCUR.

Front of instruction sheet included with each firing device.

SETTING INSTRUCTIONS

PRESSURE

25 LB OR MORE TO FUNCTION

- (1) Check safety pin for ease of removal and re-insert.
- (2) Secure switch in position with either nails, screws or wire.
- (3) Screw in coupling body assembly.
- (4) Place a suitable pressure plate in position to rest on point 'F'.
Ensure plate is not heavy enough to activate the switch.
- (5) Remove pin with **SQUARE** head using wire if necessary.
- (6) Withdraw safety pin from a safe distance using wire if necessary.
If safety pin resists movement do not withdraw. Re-check setting.

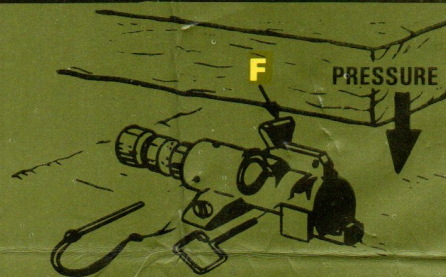

PULL

7 LB OR MORE TO FUNCTION

- (1) Check safety pin for ease of removal and re-insert.
- (2) Secure switch to a fixed object with nails, screws or wire.
- (3) Screw in coupling body assembly.
- (4) Attach trip wire to hole 'P' so that pull is in direction shown.
- (5) Remove pin with **SQUARE** head.
- (6) Withdraw safety pin from a safe distance using wire if necessary.
If safety pin resists movement do not withdraw. Re-check setting.



PRESSURE RELEASE

2 LB OR MORE TO SET BUT NOT MORE THAN 150 LBS

- (1) Check safety pin for ease of removal and re-insert.
- (2) Place switch in position and secure with either nails, screws, or wire.
- (3) Screw in coupling body assembly.
- (4) Place an object so that **at least 2 lbs. force** presses down on point 'F'.
- (5) Remove pin with **ROUND** head using wire if necessary.
- (6) Withdraw safety pin from a safe distance using wire if necessary.
If safety pin resists movement do not withdraw. Re-check setting.

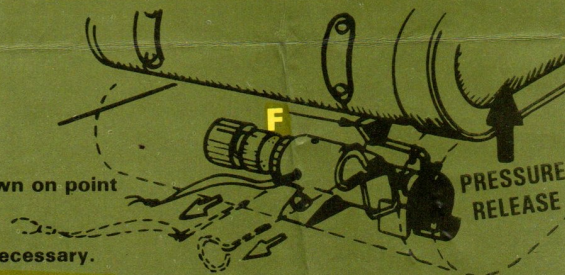

REMEMBER - REMOVE ROUND FOR RELEASE

TENSION RELEASE

- (1) Check safety pin for ease of removal and re-insert.
- (2) Secure switch to a fixed object with nails, screws or wire.
- (3) Screw in coupling body assembly.
- (4) Fit tension release device and loop end of wire over curved neck 'N'.
Adjust tension in trip wire until 'N' lines up with set point 'S'. Make sure pull is in the direction shown on the diagram.
- (5) Remove pin with **ROUND** head.
- (6) Withdraw safety pin from a safe distance using wire if necessary.
If safety pin resists movement do not withdraw. Re-check setting.



REMEMBER - REMOVE ROUND FOR RELEASE

Back of instruction sheet included with each firing device.

Detonator Kit, Concussion, M1

Type- Concussion
 Introduced- 1943-44
 Weight- 11 oz.
 Diameter- 3 in.
 Length- 5.25 in.

Development of this igniter started as a British requirement for a method to initiate several Limpet mines at the same time without the need to connect them with primacord. The SOE (Special Operations Executive) requested help from the OSS (Office of Strategic Services) in the development of a sympathetic fuze. After the OSS initiated the development, the Army and Navy found they also had use for such a device. After much research and development, the resulting device became the "M1 Concussion Firing Device". It is a mechanical device actuated by the concussion of a nearby explosion. In use, a single explosion will cause any charges equipped with the firing device within range of the initial explosion and others within range of the other devices to fire.



Detonator Kit, Concussion, M1

The body of the device is mushroom shaped and made of diecast metal. The base is a cylindrical tube that ends in a large flat head. The head is threaded to accept a protective cover that has a waffle pattern protective grill on the outer face. The waffle pattern allows the concussive wave to enter the device but still protects the inner workings from damage while in transit or handling. The head contains a release spring, phosphor bronze snap diaphragm and rubber cover. The base tube is threaded at the bottom end to accept a base coupler. The base tube contains the striker and firing pin spring. The striker has a beveled shoulder about half way down and a groove at the end to engage the release spring. Just behind the head is a cylindrical pellet sleeve cast onto the base tube. The pellet sleeve contains a safety ball, spacer, perforated sleeve plug and salt pellet. The spacer is held in place by a safety pin. The pellet sleeve is covered by a cardboard cap.

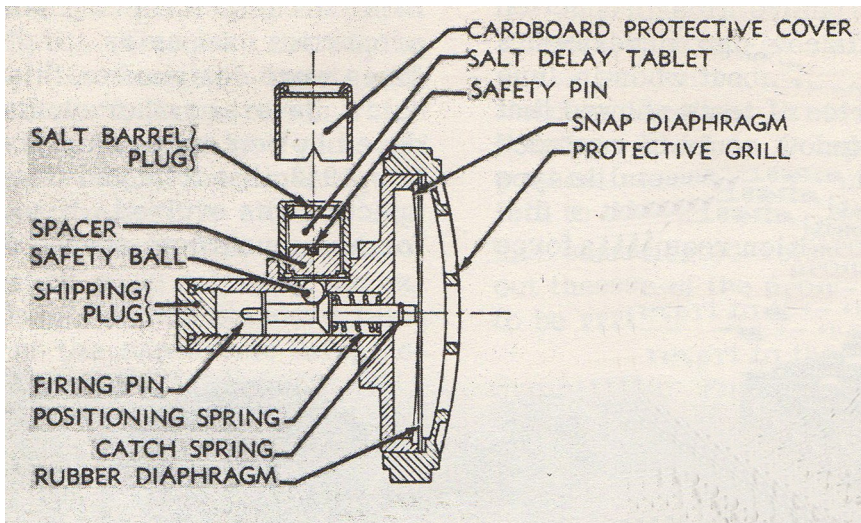

Detonator Kit, Concussion, M1 internal diagram

Inside the head, the diaphragm is in the convex position. In the safe mode, the striker is held in contact with the diaphragm by the safety ball protruding through the bottom of the pellet sleeve into the base tube with the beveled shoulder of the striker against the ball. When being emplaced in water either of two salt pellets is inserted in the sleeve plug and put into the pellet sleeve. A blue pellet will give an arming delay of approximately 3.5 minutes, the yellow pellet a delay of 7 minutes. When the safety pin

is removed and the pellet sleeve cover removed the salt pellet begins to dissolve. As it dissolves it will allow the safety ball to move upwards under pressure of the beveled shoulder and striker spring. The striker will move forward about 1/16 inch out of contact with the diaphragm and be held only by the release spring. The device is now armed. When the concussive wave from an explosion enters the head, it causes the diaphragm to invert to the concave state hitting the end of the striker and forcing it out of the release spring. The striker spring then forces the striker down to hit the percussion cap in the base coupler. When emplacing in air, the salt pellets and plug are discarded. The device will be fully armed as soon as the safety pin is removed. The device will function when a pressure of about 9 pounds per square inch is applied to the diaphragm face.

Underwater the device should not be used under 15 feet of water as the hydrostatic pressure of the water below that depth could cause the device to function.

The device is painted olive green with markings in yellow.

Demolition Firing Device Mk. 6 Mod 0

Type- Concussion
 Introduced- 1943-44
 Weight- 11 oz. w/o arming cell
 Diameter- 3 in.
 Length- 5.25 in.

This is the Naval designation for the device. Naval devices are provided with an arming cell that provides longer delay periods than the salt pellets. The arming cells screw into the device in place of the salt pellet arming delay.

The arming cells have a cylindrical body 1.71 inches long and 1.06 inches diameter. The cell contains a sea cell, locking pin and spring, locking ball and plunger. The Mk. 1 Mod. 0 provides an arming delay of 9 minutes, the Mk. 1 Mod. 1 15 minutes, the Mk. 1 Mod.

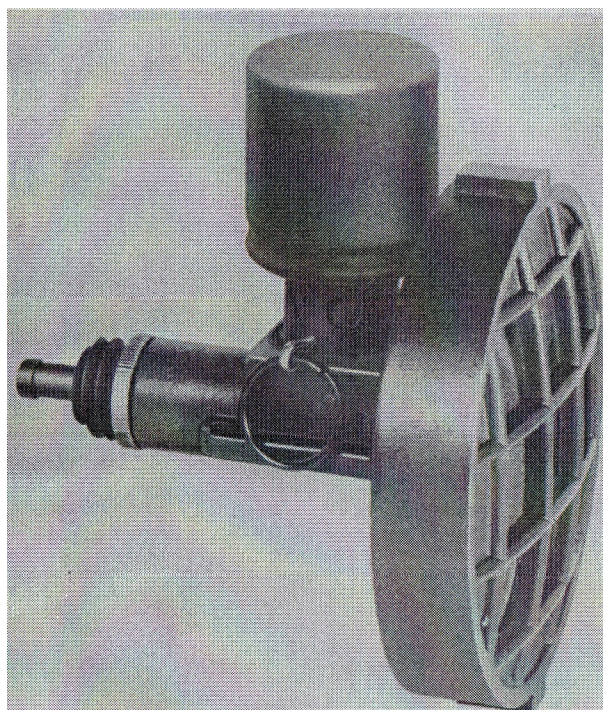

Demolition Firing Device Mk. 6 Mod 0

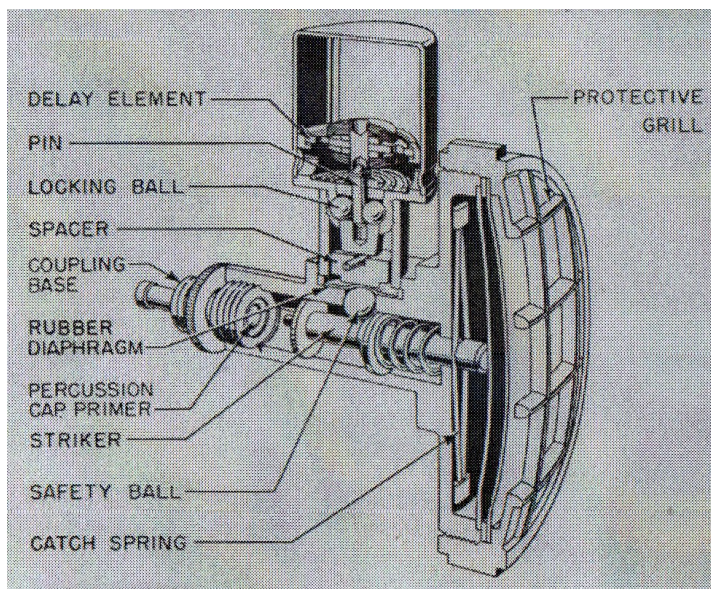

*Demolition Firing Device Mk. 6 Mod 0
 internal diagram*

2 30 minutes, the Mk. 1 Mod. 3 60 minutes, The Mk. 1 Mod. 4 90 minutes all at 60 degrees F. In later versions the Mk 1 Mod 7 arming cell provides a delay of 30 minutes and the Mk 1 Mod 8 arming cell a delay of 80 minutes at 70 degrees F. Delay times are based on immersion in sea water of average salinity. The arming times are reduced with higher temperatures and/or salinity and increase with lower temperatures and/or salinity.

Firing Device, Delay, M1

Type- Delay, Chemical
Introduced 1942
Weight- 1 oz.
Length 6 1/4 in.
Diameter- 7/16 in.

In 1942 the A.C. Gilbert Co. was manufacturing the British No. 10 Mk. I delay on behalf of the OSS. They were asked by Capt. Erhardt of the Engineer board to convert them to American standards that could be used with standard American mines and demolition blocks. This proved to be a simple task simply modifying the standard base coupler to fit the end of the device. In effect all that was required was to remove the spring snout used on the British device and replace it with the redesigned base coupler. The A.C. Gilbert Co. produced 1.8 million on the first contract another 1 million in 1943 and in 1944 were working on a contract for 2.75 million.



Firing Device, Delay, M1
Note the single inspection hole on the top (likely older) device
and the two inspection holes in the bottom device.

The device is of the chemical delay type. It consists of a two part cylindrical case, the upper section of copper, and the lower section of brass. A modified base coupler is permanently attached at the bottom end. The lower section contains the spring-loaded striker held in the cocked position by a wire running from the striker through the top section to a retaining screw at the top. Earlier production firing devices have a single inspection hole above the coloured safety strip at the lower end of the bottom section. In later production there are two inspection holes with the safety strip between them. In addition in the later production the safety strip has been moved slightly higher on the body. The top end contains a glass ampoule containing a corrosive liquid (Cupric Chloride) and two pieces of cotton wicking. The top portion of the device is sealed by plugs and by a lead washer on the retaining screw.



Closer view of the differences in
inspection holes.

Before use the device must be examined by looking through the inspection holes to ensure the striker is still held in position. If not, the device is discarded. When the device is to be used a detonator is crimped onto the base coupler. When laid the upper copper portion of the casing is crushed from both sides causing the glass ampoule to break and release the corrosive liquid. The corrosive liquid acts on the retaining wire eventually weakening it enough to break under the pressure of the striker spring. When the wire breaks, the striker, under pressure from the striker spring is forced down onto the percussion cap. The percussion cap fires and sets off the detonator.

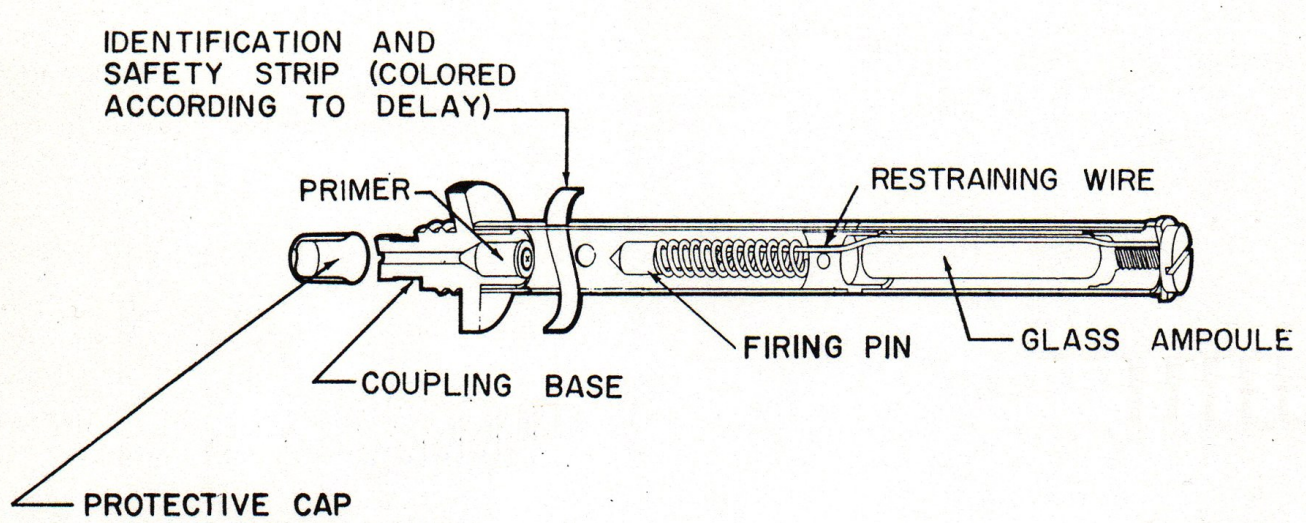

Firing Device, Delay, M1 Internal diagram

The safety strip is colour coded according to the nominal delay of the device. When initially developed there were six different delay periods. The nominal delay times for the switches were timed at 70 degrees Fahrenheit. The delay strips were painted in six different colours giving delays of: black 12 min, red 14 min. White 1 hr 45 min., Green 4 hrs, yellow, 6 hrs 15 min. and blue 17 hrs 30 min. The delay times are effected by atmospheric temperatures.

The firing device is normally unpainted, the top is natural copper coloured, the bottom portion natural brass coloured. The safety strip is painted to denote the delay times as listed above.

Two examples of packaging for M1 delays



Destructor (Demolition) Mk. 1 Mod. 0 and Mk. 1 Mod. 1

These devices were developed in 1945 primarily to provide a means to activate Japanese chemical horn type beach mines. They were used by UDT teams to locate and activate the mines after a delay giving the teams time to leave the area. The destructor provides a waterproof method of firing

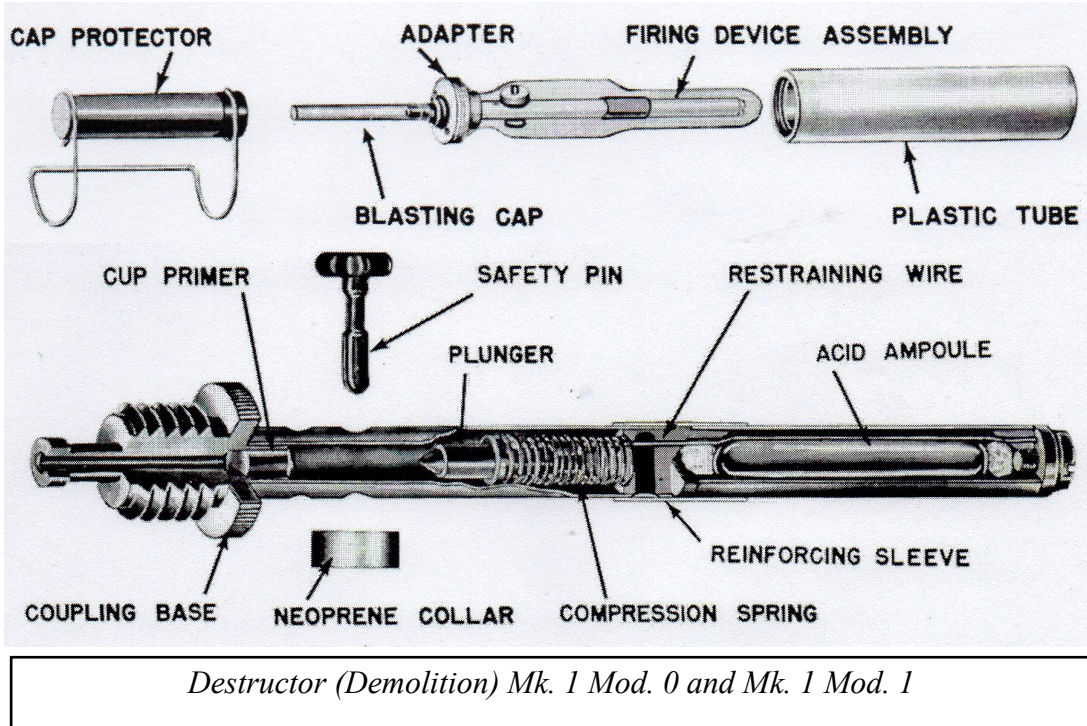

a detonator which will activate the chemical horn on the mines. Depending on the water temperature the Mk. 1 Mod 0 provides a delay of 2 to 7 hours and the Mk. 1 Mod 1 provides delays of 30 minutes to 2.5 hours.

The destructor is a modification of the "Firing Device, Delay, M1". The firing device is modified by having a safety pin inserted through the inspection holes in the side of the device, held in place by a neoprene collar. In addition, there is an adapter, rubber sheath, and a plastic tube. The adapter is made of brass and is machined to thread onto the base coupler with a rubber gasket leaving the cap extension open. There are external threads on the outside of the adapter. The rubber sheath fits over the body of the firing device and is sealed against the shoulder of the base coupler. A bulge in the sheath near the bottom end allows the safety pin to be removed without compromising the waterproofing of the device. The plastic tube fits over the device, screws onto the external threading on the adapter and protects the device during transportation. The detonator used is an Engineers special non electric blasting cap and is crimped onto the snout of the coupling base. The cap protector is a plastic case that fits over the blasting cap and threads onto the base coupler. It provides protection to the cap and acts as a muffler for the blast of the cap. A spring clip is attached to the cap protector and is used to clip the device to the horn of the mine.

The devices are Mod identified as follows:

Mk 1 Mod 0- The rubber sheath is coloured green and the end of the transportation tube is dipped in green paint. The closed end of the transportation tube has two ¼ inch square raised flats 1/16th inch high. The cap protector has a groove turned around the circumference near the bottom end.

Mk 1 Mod 1- The rubber sheath is coloured white and the end of the transportation tube is dipped in white paint. The closed end of the transportation tube has a single raised flat ¼ inch wide, 7/8 inch long, and 1/16 inch high.

For use, the devices must first be prepared by crimping the blasting cap onto the base coupler. They are normally part of a Demolition Outfit Mk 136 Mod 0 or Mod 1. The demolition outfit is simply a belt holding 10 destructors that is worn by the UDT operator. When to be used the destructor is

removed from the belt and the transportation tube removed. Crush the upper end of the device between the thumb and fingers of both hands. Remove the neoprene collar and safety pin while still in sheath ensuring that the sheath is not ruptured. If there is difficulty removing the safety pin it is assumed the device has operated and should be discarded. Snap the spring clip around the horn of the mine. Depending on the water temperature the Mk. 1 Mod 0 provides a delay of 2 to 7 hours and the Mk. 1 Mod 1 provides delays of 30 minutes to 2.5 hours. The blast produced by the blasting cap must be only of sufficient force to dent or crush the horn. The cap protector muffles the blast enough so that the proper amount of crushing force is applied to the horn without destroying or rupturing it. This allows the chemical action of the horn to detonate the mine.

Signal Relay Incendiary

The M1 Delay was also the basis of the igniter for the Pocket Incendiary M1. Basically the base coupler on the device was replaced with a celluloid capsule filled with an incendiary compound that would ignite when struck by the striker. The celluloid capsule was effected by humidity so was replaced by a magnesium capsule filled with incendiary compound and had the head of a strike anywhere kitchen match embedded in it. The normal striker was replaced with a sharper one that had been roughened by Parkerizing so that it would cause the match head to ignite and so ignite the incendiary compound. Two of these devices were attached to the pocket incendiary. They could also be used individually on easily ignited material. The A. C. Gilbert Co. produced 400,000 of these in 1943 alone.



Signal Relay Incendiary

Firing Device, Clockwork, Mk. 3

Type- Delay
Introduced 1944
Weight- 11 oz.
Height- 2 3/8 in.
Width- 2 9/16 in.
Depth- 1 1/16 in.

There was a requirement for a device to provide a more accurate time delay than that which could be obtained from time pencils or the AC delay. It was determined that a clockwork mechanism was the only logical choice. Development began in January 1943. By June 1943 the Leeds and Northrup Company using a movement made by New Haven Clock Company produced samples of a 12-hour clockwork mechanism. All interested parties found the device to be acceptable. The OSS issued a contract for 500

devices to the Automatic Temperature Control Company in October 1943. At this point, the Navy asked for 6000 devices. Because of the greater need of the Navy they took over the project and agreed to supply both the OSS and SOE. The first devices were delivered in February 1944. For

those delivered to SOE an adapter was required which was manufactured by the Burndy Engineering Company. This device was effectively obsolete by 1947.

The device consists of a cast aluminum box with a transparent plastic window in one side. All joints are equipped with gaskets or stuffing boxes to ensure it is waterproof. Magnetic protection is provided by an iron backplate. There are two tabs (one on top, one on the bottom) attached at the front by two bolts that can be bent up and used to fasten the device. The left side of the box has a "Start/Stop" thumbscrew. The right side of the box has a threaded hole (closed by a plug) to fit the firing base. The back of the case has a safety pin with locking tab and two waterproof threaded



Front face of Firing Device, Clockwork, Mk. 3



*Back of Firing Device, Clockwork, Mk. 3
24 hour version was the same*

caps covering the winding screw and setting screw. Limited instructions are embossed into the back of the case. The case contains the striker, striker spring, release mechanism, and clockwork mechanism. The clockwork mechanism is a back wound, back set type of cheap pocketwatch movement made by the New Haven Clock Company. The minute hand is retained but the hour hand is replaced by a cupped disc with a narrow slot in the circumference. The release mechanism consists of a series of sears, levers, latches and a tripping lever. The safety interrupts the striker and detonating train. The device as supplied is cocked, but unwound.

When it is to be used, the two caps on the back are removed and using the key supplied, the device is wound, and the delay set. The caps are then replaced and the device inserted into the firing train. When ready, the Start thumbscrew is rotated which gives the clockwork mechanism a kick to ensure it starts. Rotate the safety pin to remove the interrupter. The tripping lever moves down to contact the hour disk. As the clock winds down to the desired time the tripping lever comes into line with the slot in the hour disk. When aligned the lever drops into the centre of the hour disk and releases the striker. The striker under pressure of the striker spring, hits the percussion cap and starts the detonating train.

The firing device is painted olive green with markings in white.

Firing Device, Clockwork, 24 Hour

Type- Delay
Introduced 1945
Weight- 11 oz.
Height- 2 3/8 in.
Width- 2 9/16 in.
Depth- 1 1/16 in.

It was quickly determined that a device with a longer delay than that provided by the Mk. 3 was required. The OSS had the Mk. 3 worked on to provide a delay up to 24 hours. In fact all that was required was to change the disc and gearing in the movement to provide a single rotation of 24 hours. This was completed in August 1944 and the first of 1500 clocks delivered in 1945.

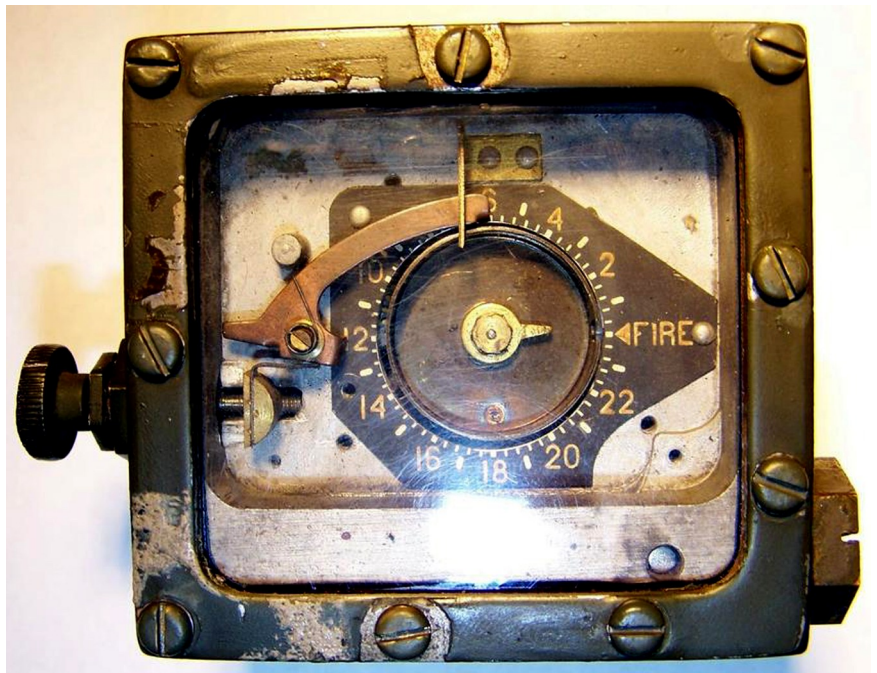

Front face of Firing Device, Clockwork, 24 hour

The only visible difference in the device is in the clock face which shows a range of settings up to 24 hours. They are otherwise identical.

This device was also obsolete by 1947.

Firing Device, Clockwork, 24 Hour (CIA)

Type- Delay
Introduced 1955
Weight- 18.5 oz.
Height- 2 3/8 in.
Width- 2 9/16 in.
Depth- 1 5/16 in

During the period 1951-1955 the CIA developed another clockwork firing device to provide a delay of up to 24 hours. The device was based on the OSS clocks and closely resembles them in form and function. This device can be used in a temperature range of -45 F to +160 F. It is waterproof to a depth of 50 feet.

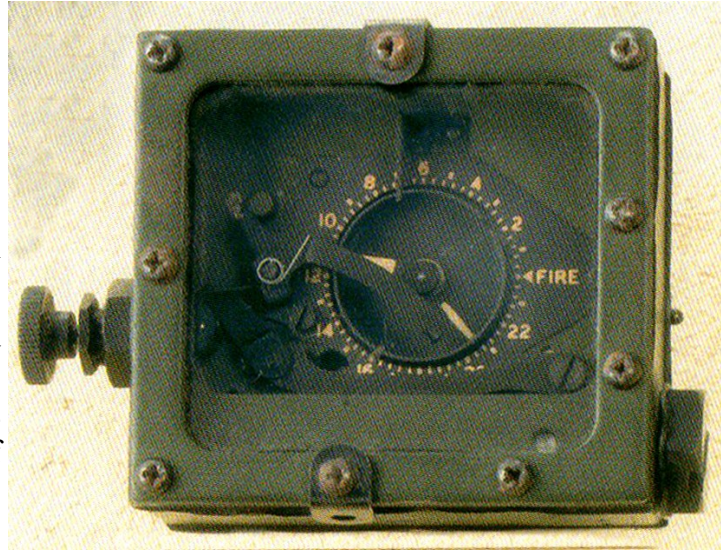

Front of Firing Device, Clockwork, 24 Hour (CIA)

The device consists of a cast zinc box with a transparent glass window in one side. There are two tabs (one on top, one on the bottom) attached at the front by two bolts that can be bent up and used to fasten the device. The left side of the box has a "Start/Stop" thumbscrew. The right side of the box has a threaded hole (closed by a plug) to fit the firing base. The back of the case has a safety pin and a single waterproof threaded brass cap covering the winding screw and setting screw. Limited instructions are embossed into the back of the case. The case contains the striker, striker spring, release mechanism, and clockwork mechanism. The clockwork mechanism is a back wound, back set type of pocketwatch movement made by the New Haven Clock Company. The minute hand is retained but the hour hand is replaced by a cupped disc with a narrow slot in the circumference. The painting of the delay increments is luminous. The release mechanism consists of a series of sears, levers, latches and a tripping lever. The safety interrupts the striker and detonating train. The device as supplied is cocked, but unwound.

The mechanism is designed to fire either of two types of primer/detonator combinations. The first is a standard coupling base and non-electric detonator. The second is the M34 detonator which requires a special stab action adapter which is supplied with the device. With these, the mechanism can be used to fire most of the explosive or incendiary devices used by the CIA at the time.

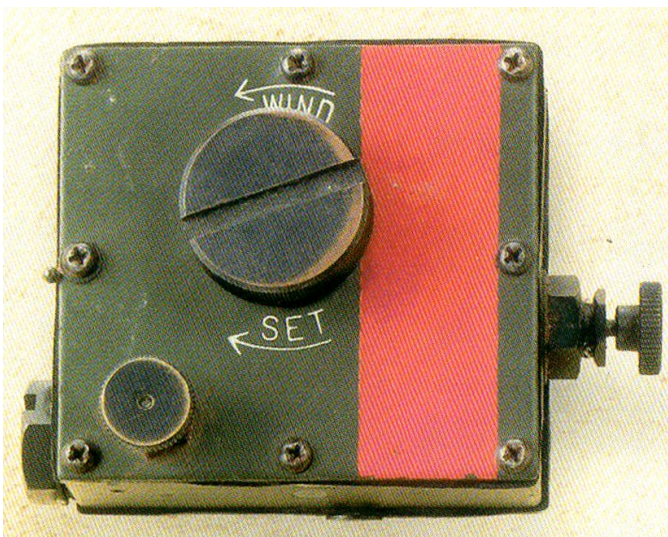

Back of Firing Device, Clockwork, 24 Hour (CIA)

The easiest method of determining whether the clockwork is a WWII OSS or later CIA device is in the single cap on the back of the device, and the use of Philips head bolts in the CIA device as opposed to the Standard (slotted) bolt heads of the WWII OSS device.

The device is supplied with all the items required for its use, winding stem, M34 adapter, standard coupling base, M34 detonator, coil of wire and a tube of obscuring compound (to cover the dial face and prevent observation of the time setting). All items are packed in a vacuum sealed can with a tear strip opening.

Demolition Firing Device Mk. 12 Mod 0/Mk. 13 Mod 0/Mk. 15 Mod 0

Type- Delay
Introduced 1946-47
Weight- 12.5 oz.
Length- 3.7 in.
Diameter- 1 3/4 in.

These devices were developed at the end of WWII or just after for the US Navy. They replaced the Mk. 3 clockwork in service. They will fire detonating cord or activator well charges. They will operate in water up to 25 feet and are designed to withstand underwater explosions of some strength. It was noted that these devices had a tendency to fire prematurely especially when set to fire after a short time interval.

The main parts of the device are the body, head, timing disc, timing disc lever, cam, firing pin, firing pin spring, release pin, and safety pin. The body is cylindrical and made of aluminum. The bottom is closed by a threaded plug that has a base coupler mounted in the centre. There is a bracket for the release pin and safety pin mounted to one side of the body. The head is also cylindrical and made of aluminum. The top half is grooved to give a gripping surface and the bottom half has the time delay increments engraved.



Demolition Firing Device Mk. 15 Mod 0



Top of device showing identification tabs indicating this is a Mk 15 Mod 0

The bottom half has the time delay increments engraved. The head is held onto to main body by three bolts through the top of the head. The body contains the remainder of the mechanism.

The device is painted olive green with marking stamped into the body and filled with white paint. Markings on the front of the device give the designation, manufacturer, lot number and inspectors number. On the side of the device is a setting line and legend. Depending on which device the legend could read "Delay in Seconds", "Delay in Minutes" or "Delay in Hours". In addition to the markings, for night identification, there are tabs attached to the top of the device by the bolts holding the head onto the body.

No tabs indicate the device is a Mk. 12 Mod. 0, one tab indicates a Mk. 13 Mod 0, and two tabs a Mk. 15. Mod 0.

The firing device is set by turning the head until the desired time is opposite the line above "Delay in Seconds/Minutes/Hours" (depending on which device is being used). Do not attempt to turn past the stop pin.

When ready for use, the safety pin is removed, this allows the release pin, under influence of a spring, to move upwards about 3/8 inch. This pulls the release pin out of a notch in the timing disc. The timing disc is driven by a pre-wound clockwork mechanism and then begins to rotate. When the desired delay is reached the timing disc lever enters the notch. When the lever enters the notch it activates a series of cams and levers to release the firing pin. The firing pin under pressure of its spring is driven down, penetrating a waterproof diaphragm to strike the percussion cap in the base coupler. The flash from the percussion cap with initiate the non-electric detonator or "Detonating Cord Initiator Mk. 2 Mod. 0".

The Mk. 12 Mod. 0 provided for delays between 5 and 90 seconds, the Mk. 13 Mod. 0 provided for delays between 1 minute and one hour, and the Mk. 15 Mod. 0 provided for delays between 15 minutes and 11 hours.

Special Note: These devices were also used by the CIA. In 1953 they issued instructions that the time settings should not be set for short delays. The Mk. 12 Mod. 0 should not be set for less than 25 seconds, the Mk. 13 Mod. 0 should not be set for less than 5 minutes and the Mk. 15 Mod. 0 should not be set for less than 2 hours. These devices remained in CIA service until the 24 Hour Clockwork firing device came into service.

Demolition Firing Device Mk. 12 Mod 1/Mk. 13 Mod 1/Mk. 15 Mod 1

Type- Delay
Introduced
Weight-
Length- 3.7 in.
Diameter- 1 11/16 in.

These devices have been modified from the original devices to make it easier to set.

The main parts of the device are the body, head, timing disc, timing disc lever, cam, firing pin, firing pin spring, release pin, and safety pin. The body is cylindrical and made of aluminum. The bottom is closed by a threaded plug that has a base coupler mounted in the centre. There is a bracket for the release pin and safety pin mounted to one side of the body. The head has been modified to have a thumb screw type grip and indicator. The time delay increment markings have been moved to the top of the body. The end of the thumb grip acts as the indicator for the time delay. Any other modifications are unknown at this time.

The device is painted olive green with marking stamped into the body and filled with white paint. Markings on the front of the device give the designation, manufacturer, lot number and inspectors number.

On the side of the device is a legend. Depending on which device the legend could read "Delay in Seconds", "Delay in Minutes" or "Delay in Hours". The time delay increments are engraved around the top of the body.

Operation of the device appears to be identical to the previous devices.



*Demolition Firing Device
Mk. 13 Mod 1*



*Demolition Firing Device
Mk. 13 Mod 1*

Demolition Firing Device, Mk 28 Mod 0

Type – Time Delay, Mechanical
Weight – 12.5oz (354.3g)
Length – 3.1 in. (78.7mm) (body only)
Diameter – 2.1in (53.3mm)

The Mk 28 Mod 0 is a mechanical, clockwork time delay firing device that can be used to attack land or marine targets. It is normally employed with the Mk 17 Mod 0 detonating cord initiating coupler.

The body is aluminum and has a plastic time selector knob. The body of the device contains a time select mechanism, firing mechanism, cam, cam follower, striker, and striker spring. The time selector knob has a metal arming pin. Early versions of the device were fitted with a base coupler requiring the user to crimp a nonelectric blasting cap (detonator) to the coupler. The introduction of the Mk 17 Mod 0 detonation cord initiating coupler replaced the older design. The Mk 17 Mod 0 has a coupling device with a stab-sensitive primer and a factory-crimped nonelectric blasting cap. The Mk 17 Mod 0 is contained in a plastic container with the blasting cap surrounded by 2in (50.8mm) of foam to protect it. There are two holes in the container to allow the insertion of detonating cord. The packing foam is configured to allow the detonating cord to contact the blasting cap.

The Mk 28 Mod 0 has a chemically treated black, or very dark blue, body. The top of the firing device has a decal reading, "MULTIPLY INDICATED SETTING BY 10 MINUTES." The body of the device is stenciled in red, "U.S. NAVY NAVORDSYSCOM, FIRING DEVICE DEMOLITION MK 28 MOD 0, WT 15 OZ, SERIAL NO. xxx, WALTHAM PRECISION INSTRUMENTS."



Mk 28 Mod 0 Time Delay Firing Device

Photo – G.Zahaczewsky

To prepare the firing device for operation, the Mk 17 Mod 0 detonating cord initiating coupler is unpackaged and screwed into the bottom of the Mk 28 Mod 0. The desired detonation time is set by rotating the time selector knob, which has increments from .5 to 12. When these increments are multiplied by 10, a delay of 5 to 120 minutes can be selected. An length of detonating cord is inserted into the coupler and connected to an explosive charge.

To use the firing device, remove the arming pin from the time selector knob. Push the time selector knob upward, disconnecting it from the time selector mechanism. The time selector clockwork starts, allowing the cam and cam follower, inside the mechanism, to rotate. When the mechanism reaches the preset time, the cam follower escapes through a slot in the cam, releasing the spring-loaded striker. The striker hits the primer, initiating the blasting cap and attached explosive charge.

Firing Device, AC Delay, Mk. 1

Type- Delay
Introduced 1943
Weight- 6 oz.
Length- 4.5 in.
Diameter- 1 in.

In 1943 the OSS arranged for the production of AC delays in the US as the British were having problems producing enough. The American version is an exact copy with minor cosmetic differences. The AC delay was used throughout the remainder of WWII and was later adopted and produced by the CIA. It was also used by the Army and Navy. The AC delay saw considerable use in Viet Nam.

They are comprised of a round brass body made with a two stepped threaded end, the smaller set of threads for the burster and the larger set to screw into the limpet or charge container. It could also be fitted with a fuse cap instead of the burster. The opposite end is threaded to fit an end cap that is drilled and threaded to accept a thumb screw. The most obvious difference between the British and American production is the thumb screw. The grip on the British version is rectangular, the American is oval. A safety pin with cord attached fits through the end cap and thumb screw preventing it from being screwed in. Contained within the body is a spring loaded striker that is held in the loaded position by a celluloid disc attached to a tapered tail on the striker. Lint is packed in a brass sleeve screwed into the body just above the striker holding the striker and disc in place. American celluloid is different than British celluloid and did not work properly. Until a suitable substitute was found the OSS obtained British celluloid which was used until the end of WWII. By then a suitable substitute had been found and was used for post war production. All threaded joints are fitted with rubber washers to waterproof the device to a depth of 70 feet.

For use, the device is loaded with an ampoule containing acetone to give the desired delay time. The ampoule is loaded by removing the end cap, inserting the ampoule and replacing the end cap. When ready to initiate the device, remove the safety pin and screw the thumb screw in until the ampoule breaks. The acetone soaks into the lint and begins to work on the cellulose disc softening it. When the disc is softened enough, the striker under load of its spring will pull through the disc and fly forward to hit the cap in the burster.

The device is normally painted grey with no other markings. The thumb screw has a diamond shaped area engraved that appears to provide a firm gripping surface.

The OSS AC Delay is issued in a sheet metal box containing the device, six ampoules, a burster in a wooden container, wrench and an instruction sheet giving the nominal delay times. Depending on the temperature, the delays differ, at lower temperatures the delay times are increased, at higher temperatures the delays are shortened. As an example, at 60 degrees F the nominal delay times are: Red- 4.5 hours, Orange- 7.5 hours, Yellow- 15 hours, Green- 26 hours, Blue- 42 hours and Violet- 5.5 days. In 1944 the OSS requested asked for the development of AC delays with a delay time of up to 30 days. This was done and three more ampoules made available giving delay times to 30 days. Also, in 1944 for training, an AC delay was developed using two other ampoules giving delays of



*Firing Device, AC Delay, Mk. 1
OSS issue*



Firing Device, AC Delay, Mk. 1 (early type) in box with 10 ampoules, likely a post war CIA issue.

five minutes and 30 minutes in conjunction with a perforated disc replacing the celluloid disc. These were not issued for field use.

The CIA continued with production of the AC Delay post WWII. The CIA produced a Mk. II version in the 1950's and a Mk. III version in the 1960's. Exactly what the differences between the three versions are is unknown at this time.

One difference that can be noted from the OSS produced version to the CIA produced version is in the threaded cap housing the thumb screw. It appears that the WWII version has the cap knurled to provide a gripping surface, in the post WWII versions the cap is ribbed.

The CIA produced kits that contained up to 10 ampoules, Red 3 hours, Orange 7 hours, Yellow 15 hours, Green 20 hours, Violet 100 hours, Black 30 days, Clear 50 days, Gold 60 days, white unknown, grey unknown. These delay times are those given for a temperature of 77 degrees F. Delay times are increased for colder temperatures and reduced for warmer temperatures.

The CIA also introduced an incendiary head to replace the burster. The incendiary head would ignite immediately upon being struck by the striker and would burn very brightly with an intense heat for 4 to 6 minutes diminishing after that to being completely expended in 10 minutes.



Firing Device, AC Delay, Mk. 1 (Later production) in packing box. CIA issue

Firing Device, Demolition, Delay Type, Electronic, M147

Type- Delay
Introduced- 1994
Weight- 7 oz.
Length- 3.7 in.
Width- 2.2 in.
Height- 1.2 in.

The M147 is not used in general demolitions. It was primarily designed to provide Special Forces with a device that could accurately initiate a timed demolition. It is very reliable, not effected by temperature to any great degree, has accurate timing and can be used underwater. It is also hardened against outside sources of electromagnetic interference to prevent premature firing from those sources. The device covers all time ranges from 5 minutes to 30 days.

The body of the M147 is made of welded aluminum in a rectangular shape. The top of the body has a coupling nut permanently attached to allow an M7 nonelectric detonator to be attached. The detonator is not crimped onto the coupling but is held in place by a plastic coupling nut to ensure a waterproof seal. The side of the body has a safe/arming indicator in the top left corner and at the bottom the time display window. The bottom of the body has two buttons used to set the time delay. On the right side of the body is an arming tab, rotor, locking button and indicator mark. The arming tab is used to move the rotor. The rotor is marked with three letters, A (Armed), S (Safe), T (Timing).



*Firing Device, Demolition, Delay Type,
Electronic, M147*

The body contains a reserve cell battery. The battery has an extremely long life as the electrolyte is kept separate from the electrodes until the first step of the arming procedure is performed. The body also contains the clock unit, M100 electric primer, piston actuator and a safety interrupter.

For use the device is prepared by:

- lifting the arming tab 180 degrees from the body. The "S" on the rotor should be beside the indicator mark.

- Rotate the rotor 90 degrees until the "T" is beside the indicator mark. This activates the battery. The LCD display should read all 8's, diamond symbols and underscores.

- The time is set by pushing the left button once so the display goes blank, press it once more and the display will read all zeros with a 5 on the right. An underscore(cursor) will be under the left hand zero. Each time the left button is pushed the cursor moves one position to the right. There are three sets of two digits representing days/hours/minutes reading from the left. To set the time position the cursor under the digit desired and hold the left button down, press the right button to change the digit. Each press on the right button moves an increment of one. Release and press the left button to move to the next digit. Continue until the desired time is set.

- Take the arming tab in one hand and with the other press down the locking button, rotate the rotor until the "A" is aligned with the indicator mark. Check the display to ensure the minutes and seconds of the 5-minute arming delay is showing.

-Turn the rotor back to the “T” position, the arming delay will stop and the display should now show the delay time.

-Install the M7 detonator using the coupling nut.

-Arm the device by turning the rotor to the “A” position. This starts the 5-minute delay again and the display should show the countdown of the delay.

-Lower the arming tab and connect the device to the charge.

Once the 5-minute delay has elapsed the display will show a pair of flashing diamonds. The internal piston actuator functions removing the safety interrupter and putting the primer in direct line with the detonator. The safe/arming indicator changes from a green “S” to a red “A”. The device is armed and functioning. Once functioned this device cannot be stopped or reset. When the delay time expires the M147 applies power to the primer that then fires the detonator and explosive charge.

The M147 is painted olive green.

Timer, Interval, Training Kit, M45

Type- Delay

Introduced- 1994

Weight- 7 oz.

Length- 3.7 in.

Width- 2.2 in.

Height- 1.2 in.

The training device for the M147 is not a separately issued item. It one part of a kit that gives the user all the items required to effectively train in the use of the M147.

The kit is packed in an M19A1 container and consists of the following items:

Trainer- 2

Battery holder- 6

Coupling nut- 6

Rubber Bushing- 12

Inert Detonator, M7- 40

Paperboard box- 4

Cushion, Body- 1

Cushion, Lid- 1

Resealable plastic bag- 6

Instruction Sheet -2

The trainer is an inert version of the M147. It is capable of performing all the functions of the M147 except setting off a detonator



Timer, Interval, Training, M45

The body is made of welded aluminum but the rotor side is capable of being removed for servicing. The top of the body has a coupling nut permanently attached to allow an inert M7 nonelectric detonator to be attached. The detonator is not crimped onto the coupling but is held in place by a plastic coupling nut to ensure a waterproof seal. Beside the coupling nut is a safe-arming button used to manually set the safe and armed state. The side of the body has a safe/arming indicator in the top left corner, at the bottom is the time display window. The bottom of the body has two buttons used to set the time delay. On the right side of the body is an arming tab, rotor, locking

button and indicator mark. The tab is used to move the rotor. The rotor is marked with three letters, A (Armed), S (Safe), T (Timing). The back of the device has a reset switch that resets the device to a non-functioning mode. The left side of the body has a battery cover used to replace the four batteries required to power the device.

Operation of the device is exactly the same as the M147 except that it cannot fire a primer to set off a detonator. Instead an internal buzzer will sound to indicate functioning of the primer. It can also be reset for multiple uses.

The trainer is painted blue to indicate a practice item.

Igniter, Fuse, Fog Signal

Type- Pressure
Introduced- about 1942
Length- 2 in.
Diameter- 1.5 in.
Height- ½ in.

Originally developed by SOE this device was intended to closely resemble the standard railroad fog signal. It was modified so it could ignite a length of safety or instantaneous fuse attached to an explosive charge laid on the rails and so derail a train. The OSS copied the British device with several improvements.



Igniter, Fuse, Fog Signal

The device is a round brass container about 1.5 inches diameter and ½ inch in depth mounted on a teardrop shaped base plate. A spring snout is attached to the side of the container facing the small end of the tear drop. The spring snout is covered by a rubber sleeve. There is a bracket attached to the bottom of the base plate. A slot formed by the bracket allows a lead strip about 10 inches long to be inserted. The end of the bracket under the snout is bent down at 90 degrees to form a hook. Internally the container has three anvils fitted with percussion caps. The top of the container has a steel pressure plate inserted to ensure pressure is transmitted to all of the percussion caps. Quick match is wound around the anvils and the remainder of the container filled with gunpowder. In transit the spring snout was closed by a wooden plug. The device is painted grey.

To lay the device the snout must face the outside of the rail or the flange on the train wheel could cut the fuse and prevent detonation. Place the device so that the hook fits against the rail and bend the lead strip down on both sides of the rail ensuring it closely fits the rail. The fuse is inserted into the spring snout and attached to the explosive charge. When the wheel of the engine contacted the signal it would be crushed forcing the pressure plate down on the percussion caps. The percussion caps would fire and ignite the quick match and the gunpowder filling. This would send a flash of flame through the snout to the fuse and ignite it.



Detonator, Friction, 15 Second Delay, M1 or M1A1

Type- Pull, Friction
Introduced 1943
Weight- 8 oz.
Length- 6 in.
Diameter- 3/4 in.



Detonator, Friction, 15 Second Delay, M1

These were introduced for use where a short delay was desirable. They

could be used in assault demolitions or rigged with a trip wire. They are waterproof and could be used underwater. No information has been found to differentiate between the M1 or M1A1.

They consist of a cylindrical plastic housing that has a friction igniter in the top end. A pull wire protruded out the top end with the bottom of the wire coated in a friction compound and embedded in a flash compound. A safety pin fits through the side of the body to hold the wire in position until ready for use. The top of the wire has a round ring attached. The bottom end of the device has a combination detonator and delay element permanently attached. The detonator element is covered by a plastic protector that screws onto the standard threading at the bottom of the top portion.

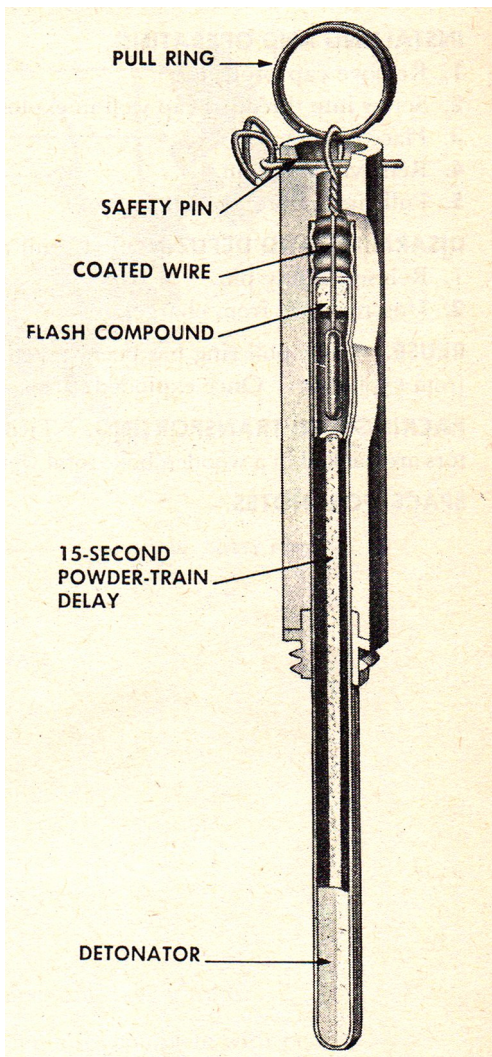

The device is made of olive drab plastic and has the delay stamped into the body. The circular ring attached to the friction wire identifies this as a 15 second delay, especially useful in low light situations.

For use, the protective cap is removed and the device screwed into a standard demolition charge. When ready for use, the safety pin is removed and the pull ring pulled out with a sharp pull. This action draws the friction wire through the flash compound causing it to ignite. The resulting flash ignites the delay element which burns down and fires the detonator.

Detonator, Friction, 15 Second Delay, M1 internal diagram

Detonator, Percussion, 15 Second Delay, M1A2

Type- Pull, Percussion
 Introduced 1959
 Weight- 3 oz.
 Length- 7 1/3 in.
 Diameter- 7/16 in.



Detonator, Percussion, 15 Second Delay, M1A2

This was a redesign of the friction detonator to one that used a percussion ignition system. They were less expensive to produce, allowed for commonality of parts during manufacture and are suitable for use underwater. It replaced the M1/M1A1 as the standard delay detonator.

The main body is made of a zinc alloy rather than the plastic of the earlier devices. The device consists of a firing assembly, delay assembly, coupling base and special detonator. The firing assembly is the top of the device consisting of a housing, firing pin, firing pin spring, release pin and positive safety pin. The firing pin is assembled into the housing with the firing pin spring compressed. The end of the firing pin protrudes from the top of the device and is held in place by the release pin with a circular ring attached. A positive safety pin fits through holes in the side of the device and blocks forward movement of the firing pin. There are three vent holes at the bottom of the housing. The delay assembly consists of a housing, a percussion primer in the top end and a delay element in the bottom end. The bottom end has a base coupler permanently attached with a detonator

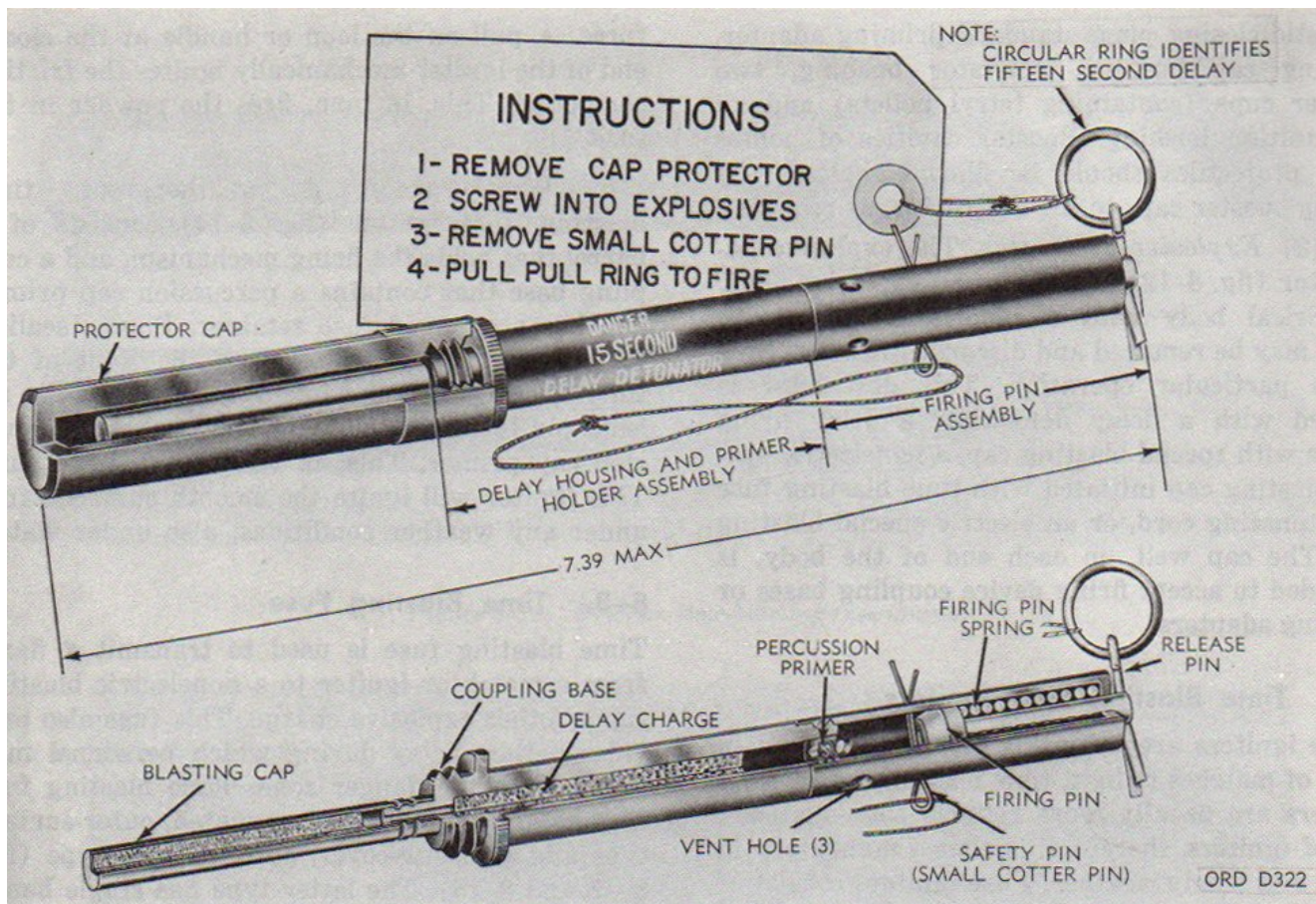

Detonator, Percussion, 15 Second Delay, M1A2 internal diagram

crimped onto the base coupler. The detonator is covered in transit by a plastic cap protector.

The device is olive green with markings in yellow. In addition to the markings, the circular ring on the release pin identifies this as a 15 second model. An instruction tag is attached to the device by a string.

When ready for use, the cap protector is removed and the device screwed into a standard demolition charge. The positive safety pin is removed and the release pin pulled. The firing pin spring reasserts itself and drives the firing pin down onto the percussion primer. When the primer fires it ignites the 15 second delay element which burns down and flashes through the base coupler into the detonator, causing it to fire.

Detonator, Friction, 8 Second Delay, M2

Type- Pull, Friction
Introduced 1945
Weight- 8 oz.
Length- 6 in.
Diameter- 3/4 in.



By 1945 it was determined that a delay detonator with a shorter delay was required.

This device was constructed in

Detonator, Friction, 8 Second Delay, M2

exactly the same manner as the 15 second delay detonator but with a shorter delay element.

They consist of a cylindrical plastic housing that has a friction igniter in the top end. A pull wire protruded out the top end with the bottom of the wire coated in a friction compound and embedded in a flash compound. A safety pin fits through the side of the body to hold the wire in position until ready for use. The top of the wire has a "T" handle attached. The bottom end of the device has a combination detonator and delay element permanently attached. The detonator element is covered by a plastic protector that screws onto the standard threading at the bottom of the top portion.

The device is made of olive drab plastic and has the delay stamped into the body. The "T" handle attached to the friction wire identifies this as an 8 second delay, especially useful for identification in low light situations.

For use, the protective cap is removed and the device screwed into a standard demolition charge. When ready for use, the safety pin is removed and the pull ring pulled out with a sharp pull. This action draws the friction wire through the flash compound causing it to ignite. The resulting flash ignites the delay element which burns down and fires the detonator.

Detonator, Friction, 8 Second Delay, M2, Inert

There were inert versions produced for training.

The inert devices are made of black plastic or are painted black with markings in white. Markings include the word "INERT".



Detonator, Friction, 8 Second Delay, M2, Inert

Detonator, Percussion, 8 Second Delay, M2A1

Type- Pull, Percussion

Introduced 1959

Weight- 3 oz.

Length- 7 1/3 in.

Diameter- 7/16 in.

This is exactly the same as the 15 second delay detonator but has a shorter 8 second delay. It replaced the M2 8 second friction delay detonator as standard.

The main body is made of a zinc alloy rather than the plastic of the earlier devices. The device consists of a firing assembly, delay assembly, coupling base and special detonator. The firing assembly is the top of the device consisting of a housing, firing pin, firing pin spring, release pin and positive safety pin. The firing pin is assembled into the housing with the firing pin spring compressed. The end of the firing pin protrudes from the top of the device and is held in place by the release pin with a "T" shaped handle attached. A positive safety pin fits through holes in the side of the device and blocks forward movement of the firing pin. There are three vent holes at the bottom of the housing. The delay assembly consists of a housing, a percussion primer in the top end and a delay element in the bottom end. The bottom end has a base coupler permanently attached with a detonator crimped onto the base coupler. The detonator is covered in transit by a plastic cap protector.

The device is olive green with markings in yellow. In addition to the markings, the "T" shaped handle on the release pin identifies this as an 8 second model. An instruction tag is attached to the device by a string.

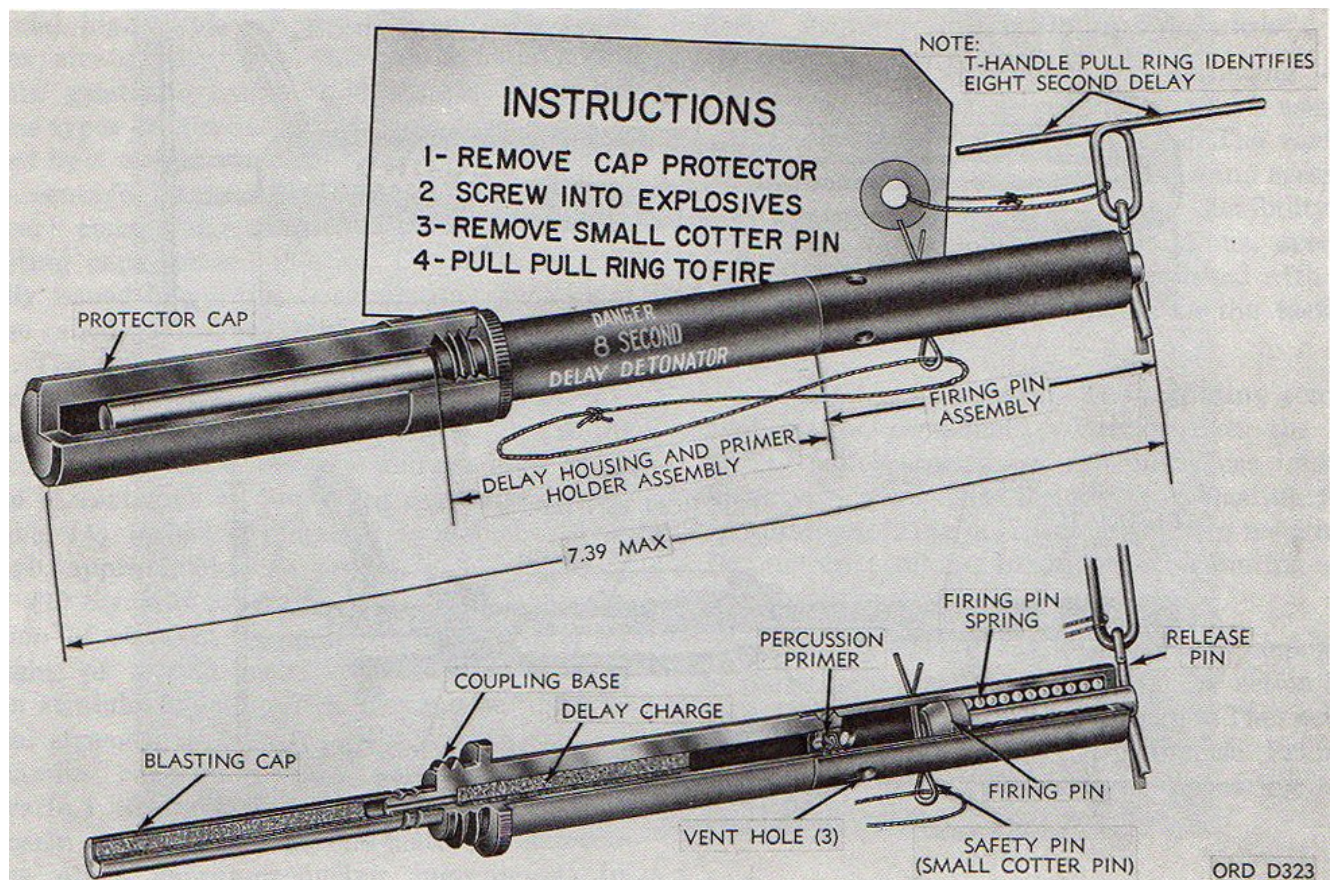

Detonator, Percussion, 8 Second Delay, M2A1 internal diagram

When ready for use, the cap protector is removed and the device screwed into a standard demolition charge. The positive safety pin is removed and the release pin pulled. The firing pin spring reasserts itself and drives the firing pin down onto the percussion primer. When the primer fires it ignites the 8 second delay element which burns down and flashes through the base coupler into the detonator, causing it to fire.

Fuse Lighter, M1

Type- Friction
Introduced prior to WWII
Length- 3 5/16 in.
Diameter- 5/16 in.

This fuse lighter was introduced prior to WWII as a method of igniting time/safety fuse without the use of matches. Mostly replaced by the M2 Lighter by the end of WWII, it continued in use until the 1950's. It is not weatherproof but it was more wind resistant and reliable than using matches to ignite fuse.

The lighter consists of a cardboard tube with one end closed by a staple. The other end has metal teeth inserted that will allow a fuse to be pushed in but will not allow it to be removed without force. The firing wire protrudes out the closed end between the staple and has a short handle or loop on the end. The body contains a red phosphorous ignition compound. The firing wire is coated with a friction compound with the wire loosely coiled and embedded in the ignition compound.

When the fuse is inserted it is pushed fully up in the tube. When ready to fire, one hand should grasp the body of the lighter rather than the fuse. The other hand grasps the handle on the firing wire and pulls with a sharp pull to draw the wire through the ignition compound. The friction compound on the wire causes the ignition compound to ignite and light the fuse.



Fuse Lighter, M1

Lighter, Fuse, Weatherproof, M2

Type- Percussion
Introduced 1943
Length- 3 ¼ in.
Diameter- ½ in.

In August 1943 The A. C. Gilbert Co. developed this lighter in collaboration with Mr. J. P. Roysdon of the Engineer Board. The M2 Fuse Lighter was more weatherproof than the earlier M1

Lighter and basically replaced it in use by the end of the war. It was waterproof, could ignite fuse underwater and would also ignite fuse at night without showing a flash. The A. C. Gilbert Co. produced the first contract of 5000 in 1943 and eventually received contracts for over 6 million of the devices.

The lighter consists of a zinc alloy body, steel striker and striker spring, release pin, and special base coupler. The body is a tube turned over on one end and internally threaded at the other. The striker is a simple shaft with a striker head on the bottom and a hole through the top end. The striker is forced up against the spring until the end protrudes out the top end and the safety pin can be inserted. The special base coupler has a spring snout to hold the fuse but it is covered by a shroud for its entire length. The shroud helps in weatherproofing it and preventing flash if used at night.

The lighter is issued complete and ready to use right out of the box. For use, simply insert the end of the fuse in the coupler and push fully home. The spring snout will grip the fuse and prevent its removal. When ready, simply pull out the release pin which will release the striker to fly down, propelled by the striker spring to hit the primer in the base coupler. The primer flash will ignite the fuse.

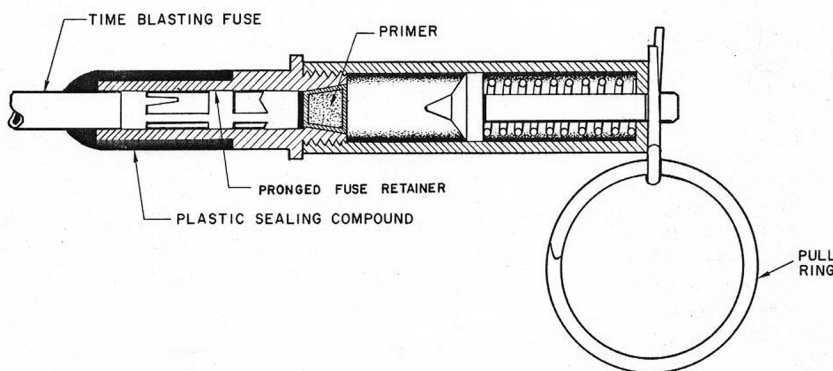

Lighter, Fuse, Weatherproof, M2 internal diagram

The lighters were packed in cardboard cartons with a label on the top that stated "NOTE: TO BE USED ONLY FOR FRONT LINE DEMOLITIONS OR UNDER ADVERSE WEATHER CONDITIONS". When packed there is a cardboard tube covering the base coupler and a rubber plug in the end of the base coupler. The lighters are painted olive green or black with markings in yellow or white.

Lighter, Fuse, Weatherproof, M2 Inert

There were inert versions produced for training. These are exactly the same as a live lighter but have no live components (primer). They are identified by being painted black with markings in white that specifically include the word "Inert".



Lighter, Fuse, Weatherproof, M2 Inert



Lighter, Fuse, Weatherproof, M2 with cardboard protector

Igniter, Time Blasting Fuse, Weatherproof, M60

Type- Percussion
Introduced 1959
Weight- 1.2 oz.
Length- 4 3/8 in.
Diameter- 3/4 in.

Development of the M60 fuse lighter began in 1953 to design an item to reliably ignite M700 safety fuse in air or underwater. It was intended to replace the M2 fuse lighter that had several shortcomings. The development item was designated T2. In March 1959 the T2 was judged to be a satisfactory item and was standardized as "Igniter, Time Blasting fuse, Weatherproof, M60".



Igniter, Blasting Fuse, Weatherproof, T2

The lighter consists of the main housing which is a closed end nylon plastic tube threaded externally on both ends. The closed end has a hole through the centre. The firing assembly consists of a threaded cap, pull rod, striker, striker spring, release washer, pull ring, and safety pin. The threaded cap screws onto the closed end of the main housing and has a hole through the centre to fit the pull rod. The pull rod is a steel shaft with a tapered head. There are four holes in the shaft, one at the top to fit the pull ring, one about a half inch down to fit the safety pin, one drilled up through the centre of the shaft from the tapered head and finally one drilled half way through the side of the shaft to intersect the hole from the head. The striker is made in two parts, the striker head which is crimped into the shaft of the striker. The shaft has a tapered ridge formed inside the open end and has four splits running from the open end about 2/3 the length of the shaft. The striker spring is a simple coil spring about 2.5 inches long. The release washer is a metal washer with a small shaft on one side. When assembled the pull rod is inserted into the striker and held in place by the ridge in the striker shaft and the head on the pull rod. The assembly is then inserted through the spring and the release washer placed over the end of the pull rod with its small shaft facing the striker. The whole assembly is then inserted into the main housing with the pull rod passing through the central hole. A rubber washer is placed over the pull rod and the threaded cap screwed on. The safety pin is inserted through the threaded cap and through the pull rod. This holds the assembly in place with little compression on the spring. Finally the pull ring is inserted through the hole in the pull rod. The



Igniter, Time Blasting Fuse, Weatherproof, M60

primer assembly consists of a plastic holder with a percussion primer inserted. This assembly is inserted into the open end of the main housing with a small washer and is held in by a rubber grommet. The fuse holder assembly consists of the threaded end cap, two piece tapered collet, larger washer and a shipping plug. The inside of the threaded cap has a tapered socket formed inside leading to the hole in the end. The collet fits into the tapered

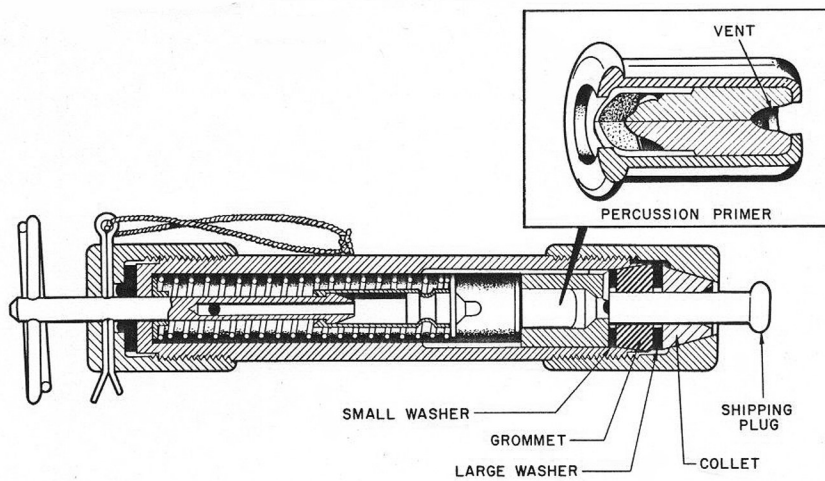

*Igniter, Time Blasting Fuse, Weatherproof, M60
internal diagram*

socket with the shipping plug inserted through the end. The large washer is placed inside and the assembly screwed onto the main housing. As the cap is screwed on, the large washer is pushed down on top of the collet forcing it into the tapered socket causing it to tighten against the shipping plug. Once assembled the device is water and air tight.

For use, the cap with the shipping plug is loosened off, the shipping plug removed and safety fuse inserted through the hole and into the rubber grommet then the cap is tightened to force the collet to tighten around the fuse and at the

same time compressing the rubber grommet to make a waterproof seal. When ready to fire, the safety pin is removed and the pull ring pulled. This causes the moving parts of the firing assembly to pull out, compressing the spring. When the shaft of the striker comes into contact with the release washer, the small shaft on the washer enters the end of the striker and pushes it out. When the shaft on the striker is forced outward, it releases the head of the pull rod allowing the striker spring to reassert itself and push the striker down onto the percussion cap. The cap fires and ignites the safety fuse. The hole in the pull rod acts as a gas release for the gases formed by the firing of the percussion cap and the burning fuse.

Older manufacture of the lighters are brown with yellow markings, later manufacture is made of olive green plastic with yellow markings.

Igniter, Time Blasting Fuse, Practice, Weatherproof, XM 77

- Type- Practice
- Introduced
- Weight- 1.2 oz.
- Length- 4 3/8 in.
- Diameter- 3/4 in.

The XM 77 is a practice version of the M60 fuse lighter. It is constructed exactly the same as the M60 but has no live components. It is used for training only.



Igniter, Time Blasting Fuse, Practice, Weatherproof, XM 77

While it appears that a considerable number of the XM 77 were manufactured, they do not seem to be have taken into service as standard.

The XM 77 is made of blue plastic with markings in white.

Igniter, Time Blasting Fuse, M81, w/Shock Tube Capability

Type- Percussion
 Introduced- 1997
 Length- 4 3/8 in.
 Diameter- 3/4 in.

Development of the M81 fuse lighter was undertaken to upgrade the M60 to ignite shock tube. The primer is more powerful than the one used in the M60.



Igniter, Time Blasting Fuse, XM81

The lighter consists of the main housing which is a closed end nylon plastic tube threaded externally on both ends. The closed end has a hole through the centre. The firing assembly consists of a threaded cap, pull rod, striker, striker spring, release washer, pull ring, and safety pin. The threaded cap screws onto the closed end of the main housing and has a hole through the centre to fit the pull rod. The pull rod is a steel shaft with a tapered head. There are four holes in the shaft, one at the top to fit the pull ring, one about a half inch down to fit the safety pin, one drilled up through the centre of the shaft from the tapered head and finally one drilled half way through the side of the shaft to intersect the hole from the head. The striker is made in two parts, the striker head which is crimped into the shaft of the striker. The shaft has a tapered ridge formed inside the open end and has four splits running from the open end about 2/3 the length of the shaft. The striker spring is a simple coil spring about 2.5 inches long. The release washer is a metal washer with a small shaft on one side. When assembled the pull rod is inserted into the striker and held in place by the ridge in the striker shaft and the head on the pull rod. The assembly is then inserted through the spring and the release washer placed over the end of the pull rod with its small shaft facing the striker. The whole assembly is then inserted into the main housing with the pull rod passing through the central hole. A rubber washer is placed over the pull rod and the threaded cap screwed on. The safety pin is inserted through the threaded cap and through the pull rod. This holds the assembly in place with little compression on the spring. Finally the pull ring is inserted through the hole in the pull rod. The primer assembly consists of a plastic holder with a percussion primer inserted. This assembly is inserted into the open end of the main housing with a small

washer and is held in by a rubber grommet. The fuse holder assembly consists of the threaded end cap, two-piece tapered collet, larger washer and a shipping plug. The inside of the threaded cap has a tapered socket formed inside leading to the hole in the end. The collet fits into the tapered socket with the shipping plug inserted through the end. The large washer is placed inside and the assembly screwed onto the main

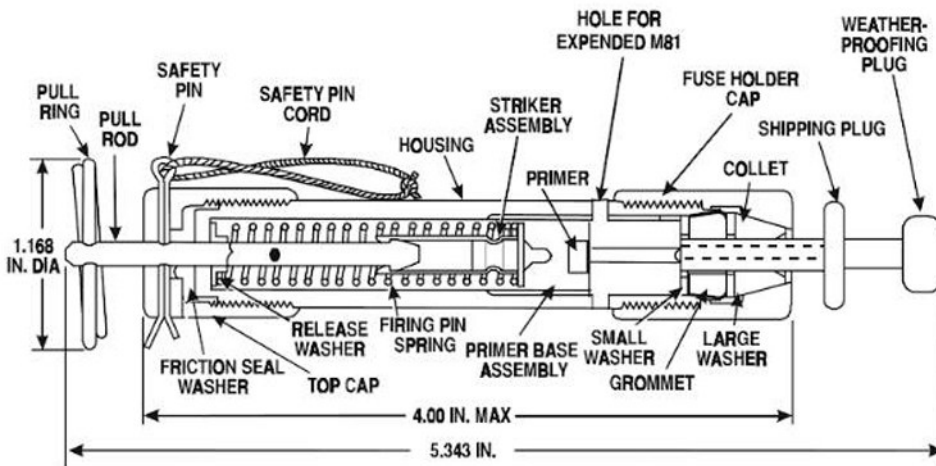

Igniter, Time Blasting Fuse, M81 internal diagram

housing. As the cap is screwed on, the large washer is pushed down on top of the collet forcing it into the tapered socket causing it to tighten against the

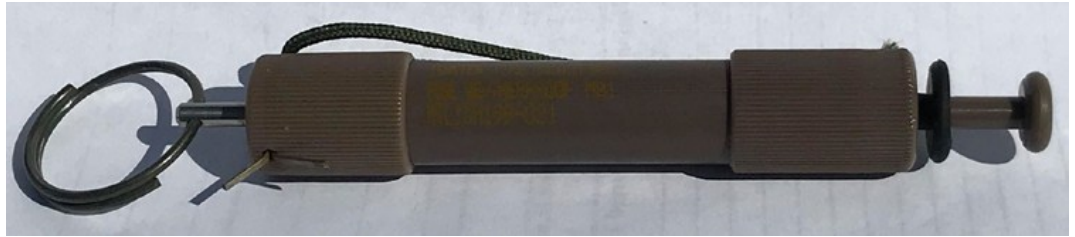

Igniter, Time Blasting Fuse, M81

shipping plug. The shipping plug is two part, the outer part closes the end of the lighter and if removed allows normal safety fuse to be inserted into the lighter. The inner plug can be removed without taking out the outer plug and allows shock tube to be inserted and held securely. Once assembled the device is water and air tight.

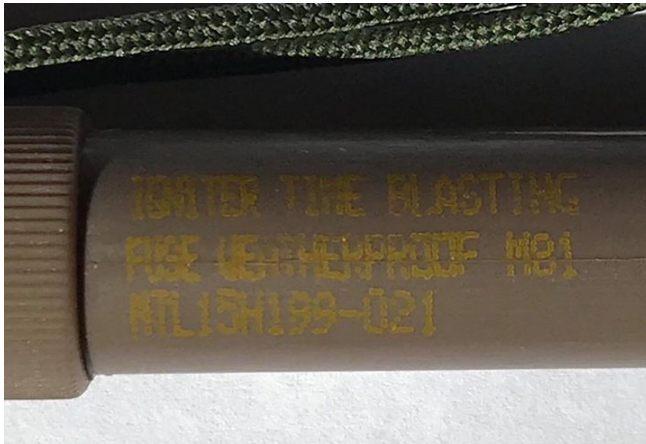

Igniter, Time Blasting Fuse, M81 markings

with the release washer, the small shaft on the washer enters the end of the striker and pushes it out. When the shaft on the striker is forced outward, it releases the head of the pull rod allowing the striker spring to reassert itself and push the striker down onto the percussion cap. The cap fires and ignites the safety fuse or shock tube. The hole in the pull rod acts as a gas release for the gases formed by the firing of the percussion cap and the burning fuse.

The lighter is made of olive green nylon plastic and has markings in yellow. The shipping plugs are white and olive green. The larger plug is white, the smaller plug is green although there are examples with differently coloured plugs.

For use, the cap with the shipping plug is loosened off and depending on what is being used, the inner (green) or outer (white) shipping plug removed and either shock tube or safety fuse inserted through the hole and into the rubber grommet, then the cap is tightened to force the collet to tighten around the fuse and at the same time compressing the rubber grommet to make a waterproof seal. When ready to fire, the safety pin is removed and the pull ring pulled. This causes the moving parts of the firing assembly to pull out, compressing the spring. When the shaft of the striker comes into contact



Label on packaging for M81

Simulator, Boobytrap, Flash, M117

Type- Pull

Introduced- prior to 1951

Weight- 0.14 lb.

Diameter- 0.98 in.

Length- 2.25 in. w/o bracket

3.9 in. w bracket

The simulator is designed for use during exercises and troop training where there is a need to provide training in the installation and use of boobytraps and to instill caution in troops exposed to traps set by the enemy. The

M117 functions with a loud report and flash. When issued the simulator is complete with the simulator, spool of trip wire, spring, three staples and four nails.



Simulator, Boobytrap, Flash, M117

The simulator consists of a cylindrical outer body made of wound paper. A flat metal nailing bracket is attached to the bottom end. A dimple in the nailing bracket is an identification marking for the M117 simulator. Contained within the outer body is a smaller tube containing the pyrotechnic compound. The ignition assembly is contained in the space between the inner and outer tubes. The assembly consists of a strip of paper coated with a friction sensitive compound and folded into a pad with the coated surfaces facing each other. A strip of felt is placed over the pad and held in place by tape wrapped around the inner tube. A pull cord runs between the coated surfaces of the pad with the end coated with a friction compound. The other end of the pull cord is coiled and placed in the top end of the body. The body is closed by a paper cap held in place by a strip of tape. A later version incorporates a safety clip to prevent inadvertent functioning of the signal.

When the simulator is set up as per instructions it will function if the wire is tripped or cut. When tripped it draws the pull cord through the pad and the friction material on the end contacts the friction sensitive compound on the pad. The flame caused then ignites the compound in the inner tube which functions with a loud bang and flash of about 700 candlepower.

The devices appear to have had several different markings over the years. The earliest devices were painted grey with a white label and markings in black. The next markings were painted white with a

white label and markings in black. Next in line are yellow with a yellow label and markings in black. The latest version appears to be unpainted with a white label and markings in black (this version is the first to have a safety clip).

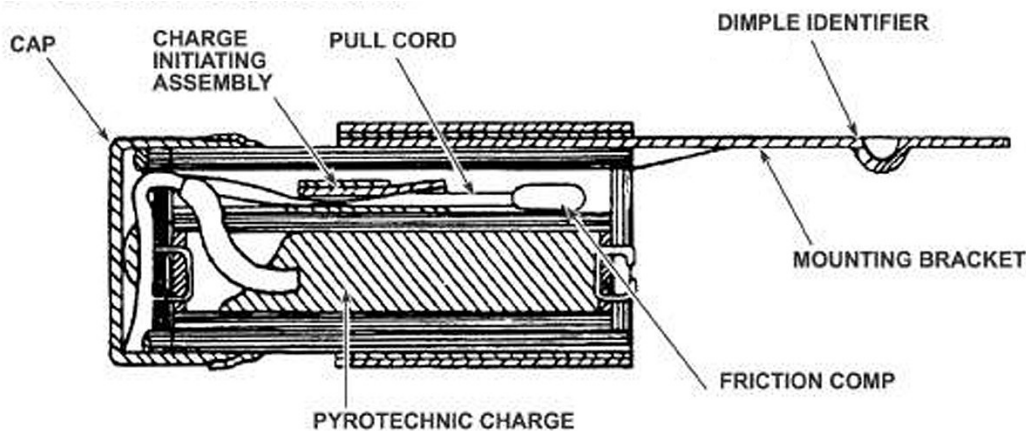

Simulator, Boobytrap, Flash, M117 internal diagram

Simulator, Boobytrap, Illumination, M118

Type- Pull
Introduced- prior to 1951
Weight- 0.14 lb.
Diameter- 0.98 in.
Length- 2.25 in. w/o bracket
3.9 in. w bracket

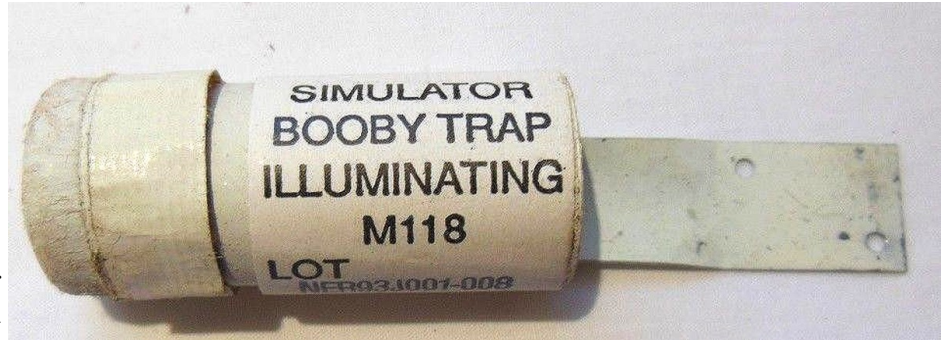

Simulator, Boobytrap, Illumination, M118

The simulator is designed for use during exercises and troop training where there is a need to provide training in the installation and use of

boobytraps and to instill caution in troops exposed to traps set by the enemy. The M118 functions with a illumination flame for a period of 30 seconds. When issued the simulator is complete with the simulator, spool of trip wire, spring, three staples and four nails.

The simulator consists of a cylindrical outer body made of wound paper. A flat metal nailing bracket is attached to the bottom end. Contained within the outer body is a smaller tube containing the flare composition. The ignition assembly is contained in the space between the inner and outer tubes. The assembly consists of a strip of paper coated with a friction sensitive compound and folded into a pad with the coated surfaces facing each other. A strip of felt is placed over the pad and held in place by tape wrapped around the inner tube. A pull cord runs between the coated surfaces of the pad with the end coated with a friction compound. The other end of the pull cord is coiled and placed in the top end of the body. The body is closed by a paper cap held in place by a strip of tape. A later version incorporates a safety clip to prevent inadvertent functioning of the signal.

When the simulator is set up as per instructions it will function if the wire is tripped or cut. When tripped it draws the pull cord through the pad and the friction material on the end contacts the friction sensitive compound on the pad. The flame caused then ignites the flare compound in the inner tube which burns for a period of 30 seconds.

The devices appear to have had several different markings over the years. The earliest devices were painted grey (1950's to early 60's) with a white label and markings in black. The next markings were painted white (early 60's to early 90's) with a white label and markings in black. Next in line are yellow (90's to 2000's) with a yellow label and markings in black. The latest version appears to be unpainted with a white label and markings in black (this version is the first to have a safety clip).

Simulator, Boobytrap, Whistling, M119

Type- Pull

Introduced- prior to 1951

Weight- 0.15 lb.

Diameter- 0.98 in.

Length- 2.81 in. w/o bracket

4.4 in. w bracket

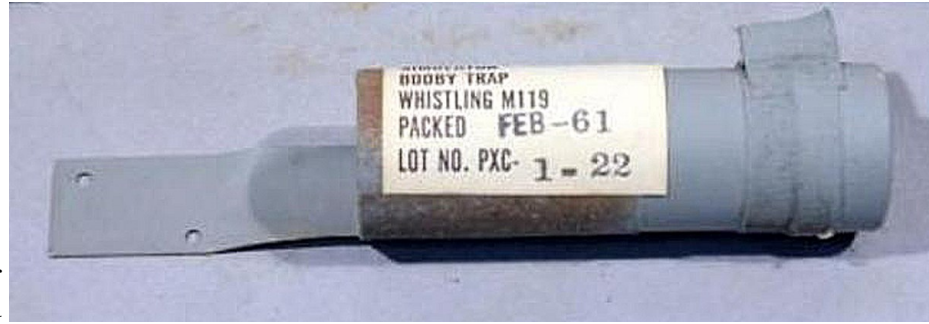

Simulator, Boobytrap, Whistling, M119 (dated 1961)

The simulator is designed for use during exercises and troop training where there is a need to provide training in the installation and use of

boobytraps and to instill caution in troops exposed to traps set by the enemy. The M118 functions with a whistle for a period of 3-4 seconds. When issued the simulator is complete with the simulator, spool of trip wire, spring, three staples and four nails.

The simulator consists of a cylindrical outer body made of wound paper. A flat metal nailing bracket is attached to the bottom end. Contained within the outer body is a smaller tube containing a slow burning composition that produces a whistle by liberating gas in the paper tube. The ignition assembly is contained in the space between the inner and outer tubes. The assembly consists of a strip of paper coated with a friction sensitive compound and folded into a pad with the coated surfaces facing each other. A strip of felt is placed over the pad and held in place by tape wrapped around the inner tube. A pull cord runs between the coated surfaces of the pad with the end coated with a friction compound. The other end of the pull cord is coiled and placed in the top end of the body. The body is closed by a paper cap held in place by a strip of tape. A later version incorporates a safety clip to prevent inadvertent functioning of the signal.



Packaging and accessories issued with the M119

When the simulator is set up as per instructions it will function if the wire is tripped or cut. When tripped it draws the pull cord through the pad and the friction material on the end contacts the friction sensitive compound on the pad. The flame caused then ignites the compound in the inner tube that whistles for 3-4 seconds.

The devices appear to have had several different markings over the years. The earliest devices were painted grey with a white label and markings in black. The next markings were painted white with a white label and markings in black. Next in line are yellow with a yellow label and markings in black. The latest version appears to be unpainted with a white label and markings in black (this version is the first to have a safety clip).

Coupling Base, Firing Device, M1

The Coupling base is made of zinc alloy. It is basically a holder for the primer, It is threaded on both ends with a knurled gripping ring in the middle. It is threaded on the primer end to fit standard firing devices and the other to fit demolition blocks (with threaded fuse wells) and the older grenades (9/16 UNC). The coupler will not fit the M67 grenade. On the end of the coupler opposite the primer is a nipple that can have a non-electric detonator crimped onto it.

The earliest base couplers were not provided with any protective coverings leaving the coupler susceptible to moisture, debris and water. The gripping ring is larger, 3/4 inch, and the nipple is straight sided.

The next generation couplers have a cardboard cover on the nipple which helped keep debris out of the coupler but was still susceptible to moisture and water. The gripping ring is smaller, 5/8 inch, and the nipple is straight sided with a rubber sleeve to seal the detonator.

The third generation couplers use a celluloid cover on the nipple which is far better at protecting the coupler from debris, moisture and water. The gripping ring is 5/8 inch and the nipple end is tapered and has a rubber sleeve to seal the detonator.

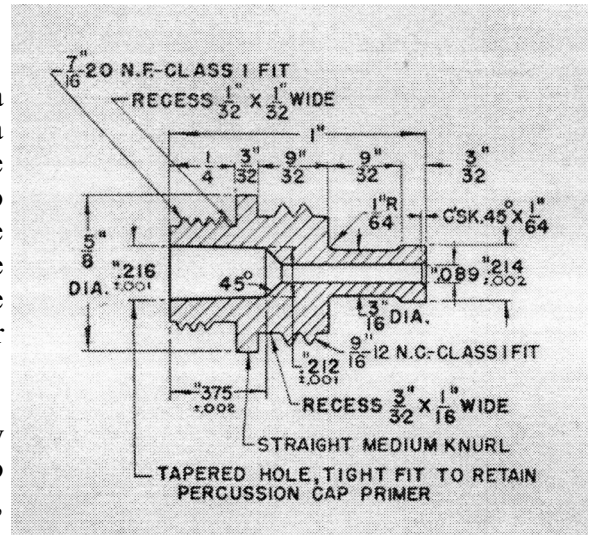

*Coupling Base, Firing Device, M1
Production drawing*



The older bases are fitted with M27 primers, newer bases are fitted with M39A1 primers.



*Coupling Base, Firing Device, M1,
earliest type on left to latest on the right*

Coupling Base, Firing Device, Non Metallic M2

This device performs the same functions as the M1 version but is designed specifically to fit an M7 non electric Blasting cap. It is threaded at one end to fit the firing devices. The other end is threaded to accept a nut that will jam the flared end of the blasting cap against the protrusion to make a waterproof seal. The nut is internally threaded to fit the base and externally threaded to fit demolition charges. A gasket on the nut ensures a waterproof seal with the demolition charges.

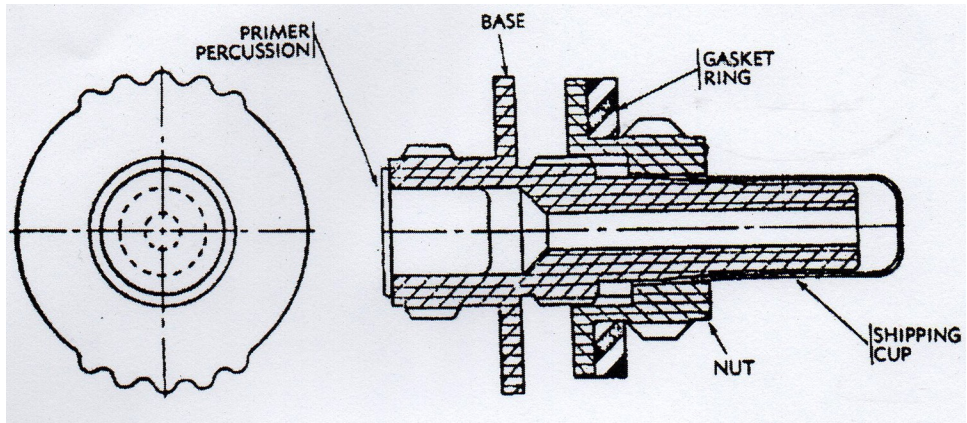

Coupling Base, Firing Device, Non Metallic M2

The coupling base is made of plastic and may be either black or olive green. It is fitted with an M39A1 primer.

Coupling body

This is normally used with the M142 Firing device but will also fit all the other US firing devices.

It is a cylindrical plastic assembly that contains an M42 primer at the firing device end and at the other end with the nut removed can be screwed into older explosive charges or with the nut and rubber gasket installed can secure either a non-electric blasting cap or time fuse with a waterproof seal.



Coupling body normally used with M142

It is made of olive green plastic and has a yellow or brown band around the centre.

Manufacturers

	US	A. C. Gilbert Co.
	US	Automatic Temperature Control Co. Philadelphia, PA
ADI	AUS	Australian Defense Industries
B&P	UK	Boon & Porter Ltd.
BUL	US	
CMZ	US	Whittaker Corp, Columbus Milpar Div.
CRC	UK	Cravens Railway Carriage and Wagon Co. Ltd. Darnall, Sheffield
CY	UK	Chorley
D over B	UK	Blackwood Trading Co., Kingston-on-Thames
EA	UK	Electric Apparatus Co., Vauxhall Works, London
EMI	UK	Electric and Musical Industries
ESS	UK	ESS Signs Ltd., Edgeware Road, Hendon
FHH	UK	
GHG	UK	G. H. Garland & Co. Ltd, Nibthwaite Road, Harrow, Middlesex, England
	US	Geometric Stamping Co. Euclid, OH
	UK	Gladhills
	US	John W. Hobbs Corp.
KYC	US	Keystone Alloys Co. Ltd.
Kynoch	UK	Kynoch Ltd.
LNO	US	
L over G	UK	Gledhill
LP	UK	Lang Pen Company Ltd., Aubrey House, Ely Place, Holborn Circus EC1
MAI	US	Maryland Assemblies Inc.
MD1	UK	Ministry of Defence 1
MDSL	UK	Mondial Defence Systems Limited.
ME	AUS	Maribyrmong Explosives
MMC	US	Marquette Corp.
MRP	NL	
MTL	US	Mast Technology Inc. Independence MO
NJD	US	Navajo Army Depot
OPI	US	Ordnance Prod Inc.
PA	US	Picatinny Arsenal
PTR	NL	
PXC	US	Ambac Ind Inc, Pace Co. Div.
RHN	US	United States Army Ammo Depot.
RM LTD	UK	
SGK	US	Security Signals Inc.
SND	US	Seneca Army Depot
SNL	US	
SPE	POR	Sociedade Portuguesa de Explosivos
	US	H.A. Sward Co. Inc.
S over J	UK	J Lucas
TGCo	UK	The Gramophone Co.
TGSR	UK	The Gramophone Co. Springfield Road
T over T	UK	Tecalamit Ltd., Brentford
UDD	US	
WWE	US	
	UK	Wembley Electric Appliances
	US	Universal Match Corp. Ferguson Mo.
Y over B	UK	Bryant and May

Credits

This is by no means a complete list of credits or references. Many other people and institutions have helped in the production of these publications.

Australian War Memorial
Darrol Vincent Bowlzer
Norman Bonney
Bernt Bosman
Mike Eldredge
Jim Geibel
Timothy Holland
Terry Keller
Kyle Kochan
Scott Lynch
Rick Larson
Leo Monkivitch
Jeff Osborne
Drew Prater
Dave Sampson
T. Mathew Smith
Colin MacGregor Stevens

George Zahaczewsky

References

Many Official Documents, Military Manuals, Training Circulars, notes and reports.

Commercial books.

Tombe Du Ciel
SOE Equipment Air dropped in Europe
Malice Aforethought
The British Spy Manual
Winston Churchills Toyshop
Station 12, SOE's Secret Centre
Secret Agents Handbook of Special Devices
The Plumber's Kitchen
OSS Weapons II, Second Edition
SOE, The Scientific Secrets

Eric Pierret
Anders Thygesen & Michael Sode
Ian Jones MBE
IWM
Stuart Macrae
Des Turner
Mark Seaman
Donald B. McLean
Dr. John W. Brunner, Ph.D.
Frederick Boyce and Douglas Everett

Websites

<http://tgrm.foxed.ca/>

<http://visualcollector.com/VisualCollectorLinks/Traps.htm>

<http://www.bocn.co.uk/vbforum/>

<http://www.millsgrenades.co.uk/>

<http://www.lexpev.nl/>

<https://www.wk2ammo.com/forum.php?s=2acb9706ceecdd4ff1a5074bde7eacd8>

<http://archives.library.wcsu.edu/findingaids/gilbert.xml>